

>85% Efficient, 255 W ATX Reference Design

A High-Efficiency GreenPoint™ Solution from ON Semiconductor

Specification	20% load	50% load	100% load
• Multiple-Output			
• Non-Redundant	85%	88%	85%
• PFC 0.9 at 50%			



Climate Savers 3

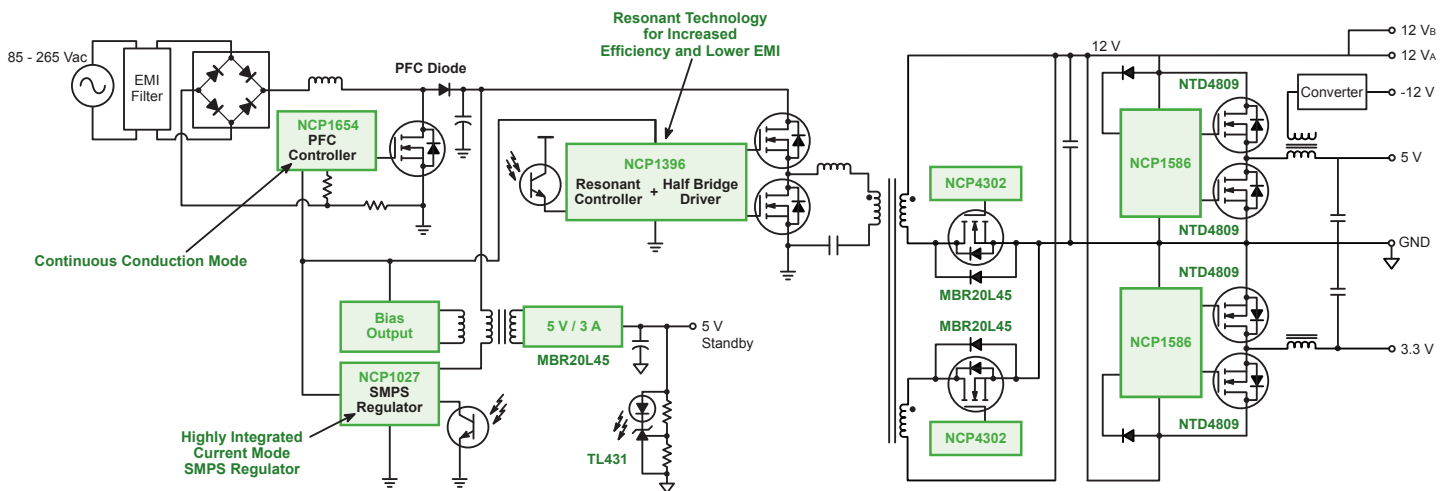

- **Efficiency > 85%**
 - @ 100, 115, 230, and 240 Vac
 - @ 25%, 50%, and 100% of load
- **Compliant with ENERGY STAR® 5.0 and Climate Savers Computing Initiative Step 3**
- **Meets IEC 61000-3-2 requirements for Power Factor >0.95 @ 100, 115, 230, and 240 Vac**
- **Production ready design: fully tested, robust, cost-effective**
- **All measurements obtained at end of 41 cm (16 in) cable**



www.onsemi.com

>85% Efficient, 255 W ATX Reference Design

A High-Efficiency GreenPoint™ Solution from ON Semiconductor

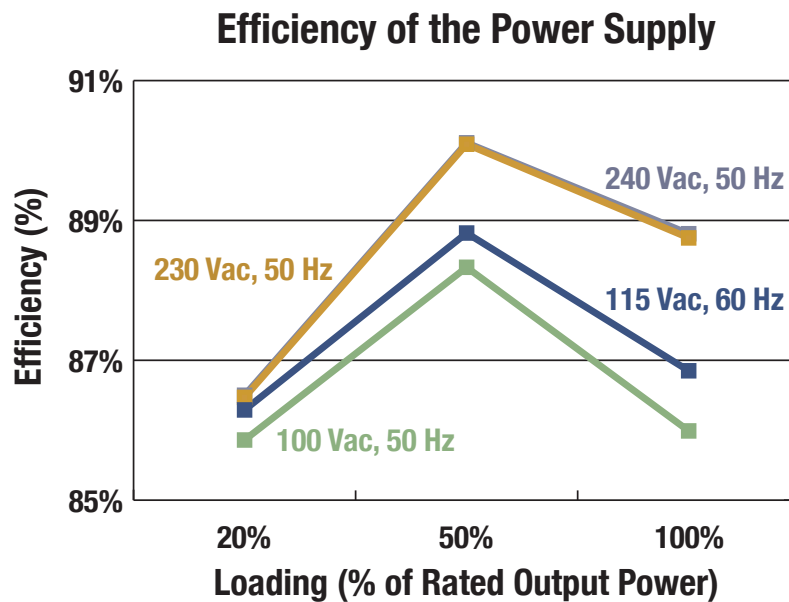

NCP1654 Continuous Conduction Mode (CCM) Power Factor Controller – Ideal solution for CCM PFC applications, such as ATX power supplies. This device enables the inclusion of a PFC front-end into an ATX power supply by simplifying the design through integration (reduced part count) and providing a robust, cost-effective front-end without range switches.

NCP1396 Resonant Mode Controller with High and Low Side Drivers – Integrated resonant tank solution, i.e., the leakage inductance of transformer acts as resonant inductance.

NCP1027 65 kHz PWM Controller featuring 700 V MOSFET – Adjustable ramp compensation feature allows deep CCM operation, optimizing efficiency at full load. Skip mode operation optimizes light load efficiency.

NCP4302 Synchronous Rectification Controller – Highly integrated secondary side controller simplifies the implementation of synchronous rectification in switchmode power supplies, improving the overall system efficiency by 2% to 4%. In addition to the SR control, the device incorporates an accurate shunt regulator with TL431 functionality, reducing board space and system cost.

NCP1586 Synchronous Buck Controller – Built in non-overlap timing control prevents cross conduction of rectification MOSFETs.

NTD4809N 30 V, 58 A, Single N-Channel Power MOSFET – Low RDS(on) minimizes conduction losses; low capacitance minimizes driver losses; optimized gate charge minimizes switching losses.

MBR20L45 20 A, 45 V L-Series Dual Schottky Rectifier – Low forward voltage drop minimizes power loss.



www.onsemi.com