

PACVGA201

VGA Port Companion Circuit

Product Description

The PACVGA201 provides seven channels of ESD protection for all signal lines commonly found in a VGA port. ESD protection is implemented with current-steering diodes designed to safely handle the high surge currents encountered with IEC-61000-4-2 Level-4 ESD Protection (± 8 kV contact discharge). When a channel is subjected to an electrostatic discharge, the ESD current pulse is diverted via the protection diodes into the positive supply rail or ground where it may be safely dissipated.

Separate positive supply rails are provided for the VIDEO, DDC_OUT and SYNC channels to facilitate interfacing with low-voltage video controller ICs and to provide design flexibility in multiple-supply-voltage environments.

An internal diode (D_1 , in schematic below) is provided such that V_{CC2} is derived from V_{CC3} (V_{CC2} does not require an external power supply input). In applications where V_{CC3} may be powered down, diode D_1 blocks any DC current path from the DDC_OUT pins back to the powered down V_{CC3} rail via the upper ESD protection diodes.

Two non-inverting drivers provide buffering for the HSYNC and VSYNC signals from the Video Controller IC (SYNC_IN1, SYNC_IN2). These buffers accept TTL input levels and convert them to CMOS output levels that swing between Ground and V_{CC3} .

When the PWR_UP input is driven LOW, the SYNC outputs are driven LOW and the SYNC inputs can float: no current will be drawn from the V_{CC3} supply.

The PACVGA201 is housed in a 16-pin QSOP package with RoHS compliant lead-free finishing.

Features

- Seven Channels of ESD Protection for All VGA Port Connector Pins
- Meets IEC-61000-4-2 Level-4 ESD Requirements (± 8 kV Contact Discharge)
- Very Low Loading Capacitance from ESD Protection Diodes on VIDEO Lines, 4pF Typical
- TTL to CMOS Level-Translating Buffers with Power Down Mode for HSYNC and VSYNC Lines
- Three Power Supplies for Design Flexibility
- Compact 16-Pin QSOP Package
- These Devices are Pb-Free and are RoHS Compliant

Applications

- ESD Protection and Termination Resistors for VGA (Video) Port Interfaces
- Desktop PCs
- Notebook Computers
- LCD Monitors



ON Semiconductor®

<http://onsemi.com>

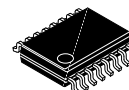

QSOP16
QR SUFFIX
CASE 492

MARKING DIAGRAM

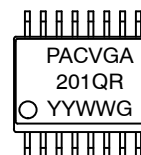

PACVGA 201QR = Specific Device Code
YY = Year
WW = Work Week
G = Pb-Free Package

ORDERING INFORMATION

Device	Package	Shipping†
PACVGA201QR	QSOP16 (Pb-Free)	2500/Tape & Reel

†For information on tape and reel specifications, including part orientation and tape sizes, please refer to our Tape and Reel Packaging Specification Brochure, BRD8011/D.

PACVGA201

SIMPLIFIED ELECTRICAL SCHEMATIC

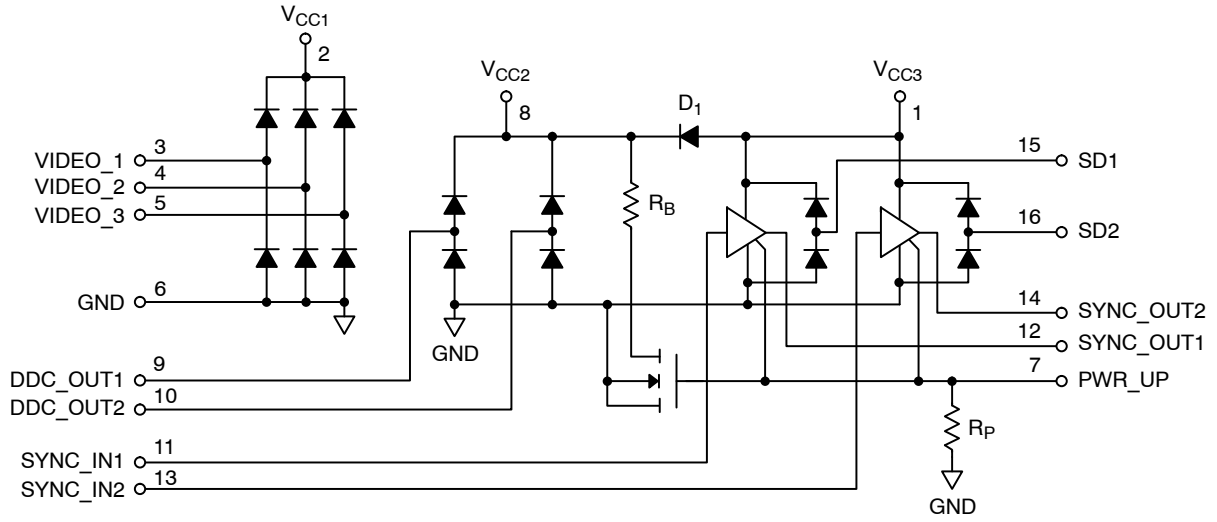

PACKAGE / PINOUT DIAGRAMS

Top View

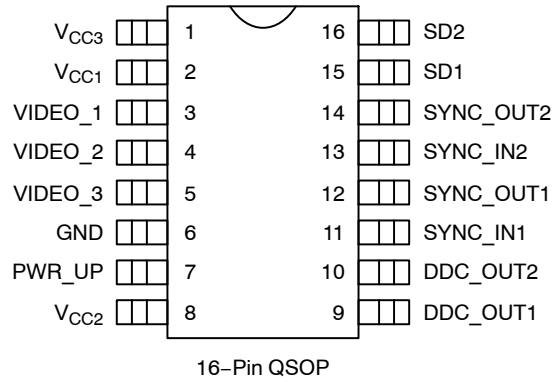

PACVGA201

Table 1. PIN DESCRIPTIONS

Pin(s)	Name	Description
1	V _{CC3}	V _{CC3} supply pin. This is an isolated supply input for the two sync buffers and SD1 and SD2 ESD protection circuits.
2	V _{CC1}	V _{CC1} supply pin. This is an isolated supply pin for the VIDEO_1, VIDEO_2 and VIDEO_3 ESD protection circuits.
3	VIDEO_1	Video signal ESD protection channel. This pin is typically tied one of the video lines between the VGA controller device and the video connector.
4	VIDEO_2	Video signal ESD protection channel. This pin is typically tied one of the video lines between the VGA controller device and the video connector.
5	VIDEO_3	Video signal ESD protection channel. This pin is typically tied one of the video lines between the VGA controller device and the video connector.
6	GND	Ground reference supply pin.
7	PWR_UP	Enables the sync buffers when high. When PWR_UP is low the sync outputs are forced low and the inputs can be floated.
8	V _{CC2}	V _{CC2} supply pin. This is an isolated supply pin for the DDC_OUT1 and DDC_OUT2 ESD protection circuits. Internally, V _{CC2} is derived from the V _{CC3} input if the V _{CC2} input is not connected to a supply voltage.
9	DDC_OUT1	DDC_OUT1 ESD protection channel.
10	DDC_OUT2	DDC_OUT2 ESD protection channel.
11	SYNC_IN1	Sync signal buffer input. Connects to the VGA Controller side of one of the sync lines.
12	SYNC_OUT1	Sync signal buffer output. Connects to the video connector side of one of the sync lines.
13	SYNC_IN2	Sync signal buffer input. Connects to the VGA Controller side of one of the sync lines.
14	SYNC_OUT2	Sync signal buffer output. Connects to the video connector side of one of the sync lines.
15	SD1	ESD protection channel input.
16	SD2	ESD protection channel input.

SPECIFICATIONS

Table 2. ABSOLUTE MAXIMUM RATINGS

Parameter	Rating	Units
V _{CC1} , V _{CC2} and V _{CC3} Supply Voltage Inputs	[GND - 0.5] to +6.0	V
Diode Forward Current (One Diode Conducting at a Time)	20	mA
DC Voltage at Inputs VIDEO_1, VIDEO_2, VIDEO_3 DDC_OUT1, DDC_OUT2 SYNC_IN1, SYNC_IN2	[GND - 0.5] to [V _{CC1} + 0.5] [GND - 0.5] to [V _{CC2} + 0.5] [GND - 0.5] to [V _{CC3} + 0.5]	V
Operating Temperature Range	0 to +70	°C
Storage Temperature Range	-65 to +150	°C
Package Power Rating	750	mW

Stresses exceeding Maximum Ratings may damage the device. Maximum Ratings are stress ratings only. Functional operation above the Recommended Operating Conditions is not implied. Extended exposure to stresses above the Recommended Operating Conditions may affect device reliability.

PACVGA201

SPECIFICATIONS (Cont'd)

Table 3. ELECTRICAL OPERATING CHARACTERISTICS (Note 1)

Symbol	Parameter	Conditions	Min	Typ	Max	Units
I_{CC1}	V_{CC1} Supply Current	$V_{CC1} = 5.0\text{ V}$			10	μA
I_{CC3}	V_{CC3} Supply Current	$V_{CC3} = 5\text{ V}$, SYNC Inputs at GND or V_{CC3} , PWR_UP pin at V_{CC3} , SYNC Outputs Unloaded		10		μA
		$V_{CC3} = 5\text{ V}$, SYNC Inputs at 3.0 V, PWR_UP Pin at V_{CC3} , SYNC Outputs Unloaded		200		μA
		$V_{CC3} = 5\text{ V}$, PWR_UP Input at GND, SYNC Outputs Unloaded			10	μA
V_{CC2}	V_{CC2} Pin Open Circuit Voltage	V_{CC2} Voltage Internally Derived from V_{CC3} via Diode D1, No External Current Drawn		$[V_{CC3} - 0.80]$		V
V_{IH}	Logic High Input Voltage	$V_{CC3} = 5\text{ V}$ (Note 2)	2.0			V
V_{IL}	Logic Low Input Voltage	$V_{CC3} = 5\text{ V}$ (Note 2)			0.8	V
V_{OH}	Logic High Output Voltage	$I_{OH} = -4\text{ mA}$, $V_{CC3} = 5.0\text{ V}$ (Note 3)	4.4			V
V_{OL}	Logic Low Output Voltage	$I_{OL} = 4\text{ mA}$, $V_{CC3} = 5.0\text{ V}$ (Note 3)			0.4	V
R_B, R_P	Resistor Value	PWR_UP = $V_{CC3} = 5.0\text{ V}$	0.5	1	2	$\text{M}\Omega$
I_{IN}	Input Current VIDEO_x Pins HSYNC, VSYNC Pins	$V_{CC1} = 5.0\text{ V}$, $V_{IN} = V_{CC1}$ or GND $V_{CC3} = 5.0\text{ V}$, $V_{IN} = V_{CC3}$ or GND			± 1 ± 1	μA
C_{IN}	Input Capacitance on VIDEO_1, VIDEO_2 and VIDEO_3 Pins	$V_{CC1} = 5.0\text{ V}$, $V_{IN} = 2.5\text{ V}$, Measured at 1 MHz $V_{CC1} = 2.5\text{ V}$, $V_{IN} = 1.25\text{ V}$, Measured at 1 MHz		4		pF
				4.5		
t_{PLH}	SYNC Buffer L \geq H Propagation Delay	$C_L = 50\text{ pF}$, $V_{CC3} = 5.0\text{ V}$, Input t_R and $t_F \leq 5\text{ ns}$		8	12	ns
t_{PHL}	SYNC Buffer H \geq L Propagation Delay	$C_L = 50\text{ pF}$, $V_{CC3} = 5.0\text{ V}$, Input t_R and $t_F \leq 5\text{ ns}$		8	12	ns
t_R, t_F	SYNC Buffer Output Rise & Fall Times	$C_L = 50\text{ pF}$, $V_{CC3} = 5.0\text{ V}$, Input t_R and $t_F \leq 5\text{ ns}$		7.0		ns
V_{ESD}	ESD Withstand Voltage	$V_{CC1} = V_{CC2} = V_{CC3} = 5\text{ V}$ (Note 4)	± 8			kV

1. All parameters specified over standard operating conditions unless otherwise noted.
2. These parameters apply only to SYNC_IN1, SYNC_IN2 and PWR_UP.
3. These parameters apply only to SYNC_OUT1 and SYNC_OUT2.
4. Per the IEC-61000-4-2 International ESD Standard, Level 4 contact discharge method. V_{CC1} , V_{CC2} and V_{CC3} must be bypassed to GND via a low impedance ground plane with a 0.2 μF or greater, low inductance, chip ceramic capacitor at each supply pin. ESD pulse is applied between the applicable pins and GND. ESD pulse can be positive or negative with respect to GND. Applicable pins are: VIDEO_1, VIDEO_2, VIDEO_3, SYNC_OUT1, SD1, SYNC_OUT2, SD2, DDC_OUT1 and DDC_OUT2. All other pins are ESD protected to the industry standard 2 kV per the Human Body model (MIL-STD-883, Method 3015).

PACVGA201

APPLICATION INFORMATION

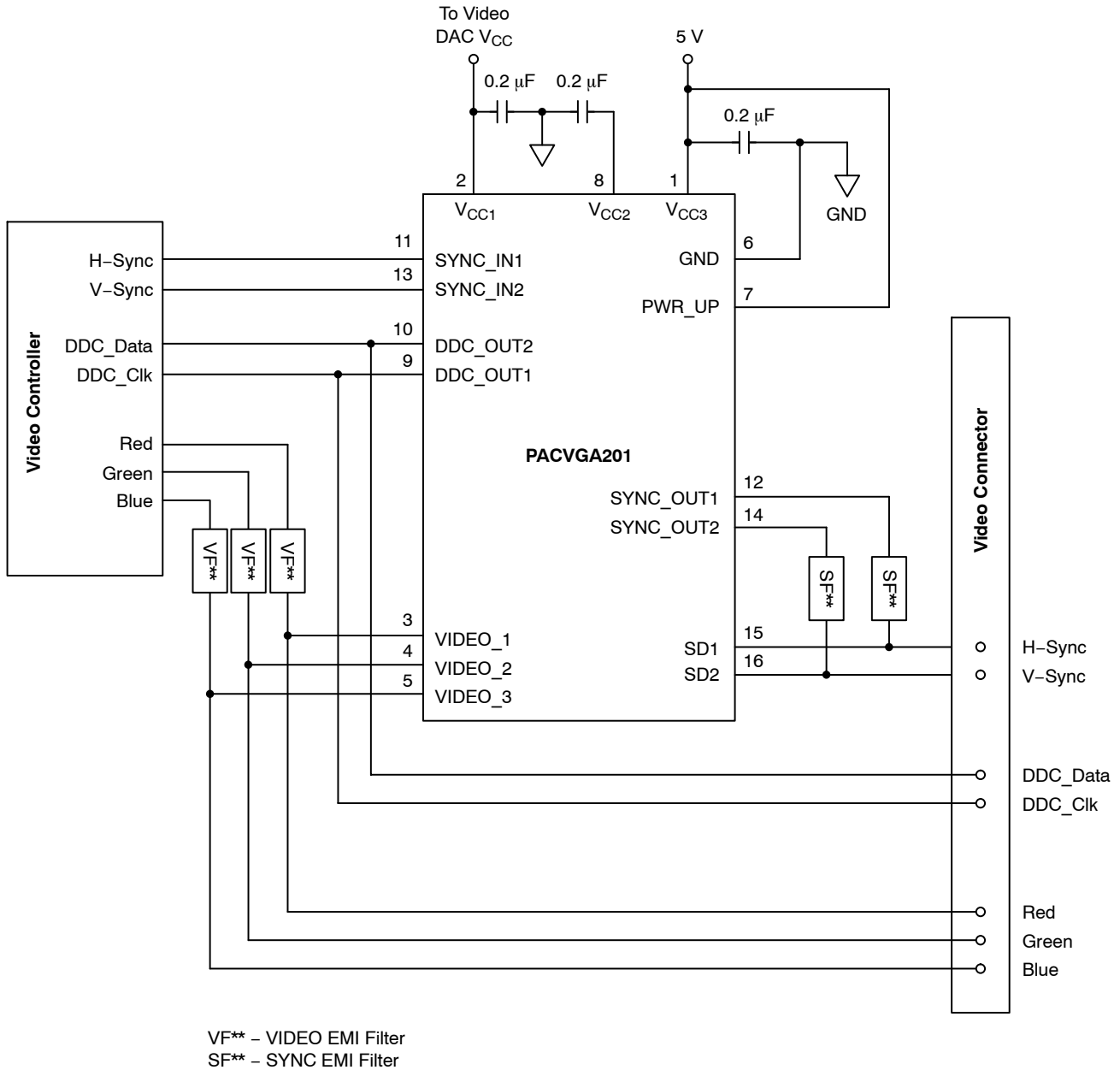

Figure 1. Typical Connection Diagram

A resistor may be necessary between the V_{CC2} pin and ground if protection against a stream of ESD pulses is required while the PACVGA201 is in the power-down state. The value of this resistor should be chosen such that the extra charge deposited into the V_{CC2} bypass capacitor by each ESD pulse will be discharged before the next ESD pulse occurs. The maximum ESD repetition rate specified by the IEC-61000-4-2 standard is one pulse per second. When the PACVGA201 is in the power-up state, an internal discharge resistor is connected to ground via a FET switch for this purpose.

For the same reason, V_{CC1} and V_{CC3} may also require bypass capacitor discharging resistors to ground if there are no other components in the system to provide a discharge path to ground.

MECHANICAL CASE OUTLINE PACKAGE DIMENSIONS

ON Semiconductor®



SCALE 2:1

QSOP16 CASE 492-01 ISSUE A

DATE 23 MAR 2011



NOTES:

1. DIMENSIONING AND TOLERANCING PER ASME Y14.5M, 1994.
2. CONTROLLING DIMENSION: MILLIMETERS.
3. DIMENSION b DOES NOT INCLUDE DAMBAR PROTRUSION.
4. DIMENSION D DOES NOT INCLUDE MOLD FLASH, PROTRUSIONS, OR GATE BURRS. MOLD FLASH, PROTRUSIONS, OR GATE BURRS SHALL NOT EXCEED 0.005 PER SIDE. DIMENSION E1 DOES NOT INCLUDE INTERLEAD FLASH OR PROTRUSION. INTERLEAD FLASH OR PROTRUSION SHALL NOT EXCEED 0.005 PER SIDE. D AND E1 ARE DETERMINED AT DATUM H.
5. DATUMS A AND B ARE DETERMINED AT DATUM H.

DIM	INCHES		MILLIMETERS	
	MIN	MAX	MIN	MAX
A	0.053	0.069	1.35	1.75
A1	0.004	0.010	0.10	0.25
A2	0.049	----	1.24	----
b	0.008	0.012	0.20	0.30
c	0.007	0.010	0.19	0.25
D	0.193 BSC		4.89 BSC	
E	0.237 BSC		6.00 BSC	
E1	0.154 BSC		3.90 BSC	
e	0.025 BSC		0.635 BSC	
h	0.009	0.020	0.22	0.50
L	0.016	0.050	0.40	1.27
L2	0.010 BSC		0.25 BSC	
M	0°	8°	0°	8°

SOLDERING FOOTPRINT

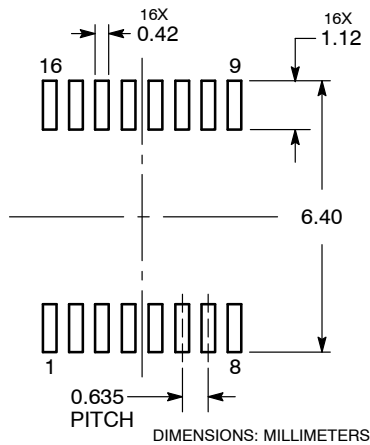

GENERIC MARKING DIAGRAM*



- XXXXXX = Specific Device Code
- YY = Year
- WW = Work Week
- G = Pb-Free Package

*This information is generic. Please refer to device data sheet for actual part marking. Pb-Free indicator, "G", may or not be present.

DOCUMENT NUMBER:	98AON04472D	Electronic versions are uncontrolled except when accessed directly from the Document Repository. Printed versions are uncontrolled except when stamped "CONTROLLED COPY" in red.
DESCRIPTION:	QSOP16	PAGE 1 OF 1

ON Semiconductor and are trademarks of Semiconductor Components Industries, LLC dba ON Semiconductor or its subsidiaries in the United States and/or other countries. ON Semiconductor reserves the right to make changes without further notice to any products herein. ON Semiconductor makes no warranty, representation or guarantee regarding the suitability of its products for any particular purpose, nor does ON Semiconductor assume any liability arising out of the application or use of any product or circuit, and specifically disclaims any and all liability, including without limitation special, consequential or incidental damages. ON Semiconductor does not convey any license under its patent rights nor the rights of others.

onsemi, **Onsemi**, and other names, marks, and brands are registered and/or common law trademarks of Semiconductor Components Industries, LLC dba "**onsemi**" or its affiliates and/or subsidiaries in the United States and/or other countries. **onsemi** owns the rights to a number of patents, trademarks, copyrights, trade secrets, and other intellectual property. A listing of **onsemi**'s product/patent coverage may be accessed at www.onsemi.com/site/pdf/Patent-Marking.pdf. **onsemi** reserves the right to make changes at any time to any products or information herein, without notice. The information herein is provided "as-is" and **onsemi** makes no warranty, representation or guarantee regarding the accuracy of the information, product features, availability, functionality, or suitability of its products for any particular purpose, nor does **onsemi** assume any liability arising out of the application or use of any product or circuit, and specifically disclaims any and all liability, including without limitation special, consequential or incidental damages. Buyer is responsible for its products and applications using **onsemi** products, including compliance with all laws, regulations and safety requirements or standards, regardless of any support or applications information provided by **onsemi**. "Typical" parameters which may be provided in **onsemi** data sheets and/or specifications can and do vary in different applications and actual performance may vary over time. All operating parameters, including "Typicals" must be validated for each customer application by customer's technical experts. **onsemi** does not convey any license under any of its intellectual property rights nor the rights of others. **onsemi** products are not designed, intended, or authorized for use as a critical component in life support systems or any FDA Class 3 medical devices or medical devices with a same or similar classification in a foreign jurisdiction or any devices intended for implantation in the human body. Should Buyer purchase or use **onsemi** products for any such unintended or unauthorized application, Buyer shall indemnify and hold **onsemi** and its officers, employees, subsidiaries, affiliates, and distributors harmless against all claims, costs, damages, and expenses, and reasonable attorney fees arising out of, directly or indirectly, any claim of personal injury or death associated with such unintended or unauthorized use, even if such claim alleges that **onsemi** was negligent regarding the design or manufacture of the part. **onsemi** is an Equal Opportunity/Affirmative Action Employer. This literature is subject to all applicable copyright laws and is not for resale in any manner.

ADDITIONAL INFORMATION

TECHNICAL PUBLICATIONS:

Technical Library: www.onsemi.com/design/resources/technical-documentation
onsemi Website: www.onsemi.com

ONLINE SUPPORT: www.onsemi.com/support

For additional information, please contact your local Sales Representative at www.onsemi.com/support/sales