

4-Bit 24 Mb/s Dual-Supply Level Translator

NLSX4378A

The NLSX4378A is a 4-bit configurable dual-supply bidirectional auto sensing translator that does not require a directional control pin. The V_{CC} I/O and V_L I/O ports are designed to track two different power supply rails, V_{CC} and V_L respectively. The V_{CC} and V_L supply rails are configurable from 1.65 V to 5.5 V. This allows voltage logic signals on the V_L side to be translated into lower, higher or equal value voltage logic signals on the V_{CC} side, and vice-versa.

The NLSX4378A translator has open-drain outputs with integrated 10 k Ω pullup resistors on the I/O lines. The integrated pullup resistors are used to pullup the I/O lines to either V_L or V_{CC} . The NLSX4378A is an excellent match for open-drain applications such as the I²C communication bus.

Features

- V_L can be Less than, Greater than or Equal to V_{CC}
- Wide V_{CC} Operating Range: 1.65 V to 5.5 V
Wide V_L Operating Range: 1.65 V to 5.5 V
- High-Speed with 24 Mb/s Guaranteed Data Rate
- Low Bit-to-Bit Skew
- Enable Input is Overvoltage Tolerant (OVT) to 5.5 V
- Nonpreferential Powerup Sequencing
- Integrated 10 k Ω Pullup Resistors
- ESD Protection: >7 kV HBM for all pins
- Small Space Saving Package – 2.02 x 1.54 mm μ Bump12
- These Devices are Pb-Free, Halogen Free/BFR Free and are RoHS Compliant

Typical Applications

- I²C, SMBus, PMBus
- Low Voltage ASIC Level Translation
- Mobile Phones, PDAs, Cameras



μ Bump12
 FC SUFFIX
 CASE 499AU

MARKING DIAGRAM

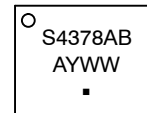

- A = Assembly Location
- Y = Year
- WW = Work Week
- = Pb-Free Package

LOGIC DIAGRAM

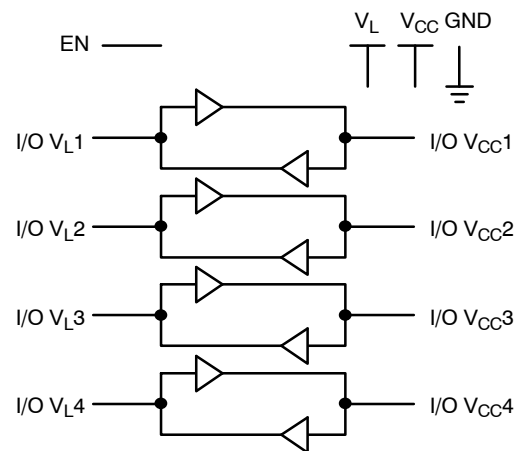

ORDERING INFORMATION

See detailed ordering and shipping information on page 8 of this data sheet.

NLSX4378A

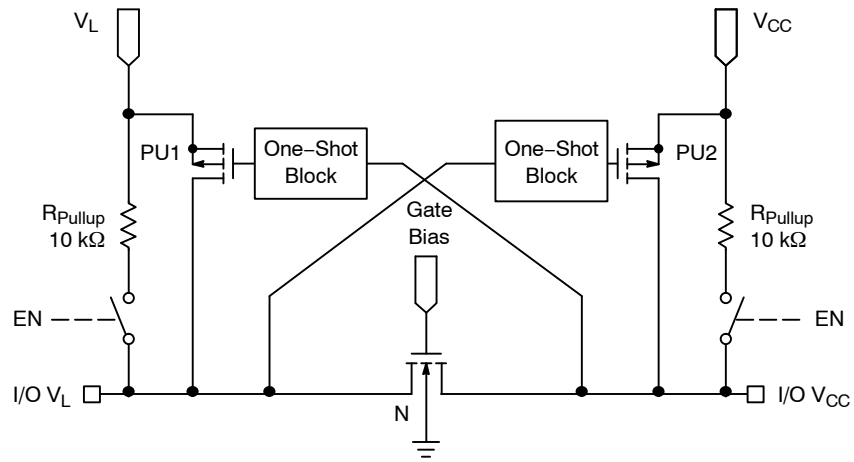

Figure 1. Block Diagram (1 I/O Line)

PIN ASSIGNMENT

Pins	Description
V _{CC}	V _{CC} Input Voltage
V _L	V _L Input Voltage
GND	Ground
EN	Output Enable
I/O V _{CCn}	V _{CC} I/O Port, Referenced to V _{CC}
I/O V _{Ln}	V _L I/O Port, Referenced to V _L

FUNCTION TABLE

EN	Operating Mode
L	Hi-Z
H	I/O Buses Connected

PIN LOCATION

Pin	Pin Name
A1	I/O V _L 1
A2	I/O V _L 2
A3	I/O V _L 3
A4	I/O V _L 4
B1	V _{CC}
B2	V _L
B3	EN
B4	GND
C1	I/O V _{CC} 1
C2	I/O V _{CC} 2
C3	I/O V _{CC} 3
C4	I/O V _{CC} 4

μBump12

(2.02 x 1.54 mm)

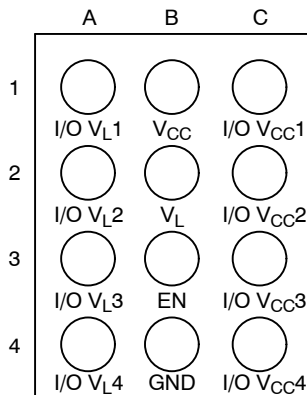

(Bottom View)

NLSX4378A

MAXIMUM RATINGS

Symbol	Parameter	Condition	Value	Unit
V _{CC}	DC Supply Voltage		-0.3 to +7.0	V
V _L	DC Supply Voltage		-0.3 to +7.0	V
I/O V _{CC}	V _{CC} -Referenced DC Input/Output Voltage		-0.3 to (V _{CC} + 0.3)	V
I/O V _L	V _L -Referenced DC Input/Output Voltage		-0.3 to (V _L + 0.3)	V
V _{EN}	Enable Control Pin DC Input Voltage		-0.3 to +7.0	V
I _{I/O_SC}	Short-Circuit Duration (I/O V _L and I/O V _{CC} to GND)	Continuous	40	mA
T _{STG}	Storage Temperature		-65 to +150	°C
I _{LU}	Latch-up Current		100	mA
ESD Rating	Human Body Model Charged Device Model		7000 2000	V

Stresses exceeding those listed in the Maximum Ratings table may damage the device. If any of these limits are exceeded, device functionality should not be assumed, damage may occur and reliability may be affected.

RECOMMENDED OPERATING CONDITIONS

Symbol	Parameter	Min	Max	Unit
V _{CC}	DC Supply Voltage	1.65	5.5	V
V _L	DC Supply Voltage	1.65	5.5	V
V _{EN}	Enable Control Pin Voltage	GND	5.5	V
V _{IO}	I/O Pin Voltage	GND	V _{CC} or V _L	V
T _A	Operating Temperature Range	-55	+125	°C

Functional operation above the stresses listed in the Recommended Operating Ranges is not implied. Extended exposure to stresses beyond the Recommended Operating Ranges limits may affect device reliability.

NLSX4378A

DC ELECTRICAL CHARACTERISTICS ($V_{CC} = 1.65\text{ V to }5.5\text{ V}$ and $V_L = 1.65\text{ V to }5.5\text{ V}$, unless otherwise specified)

Symbol	Parameter	Test Conditions	-40°C to +85°C			-55°C to +125°C		Unit
			Min	Typ (Notes 1, 2)	Max	Min	Max	
V_{IHC}	I/O V_{CC} Input HIGH Voltage		$V_{CC} - 0.4$	-	-	$V_{CC} - 0.4$	-	V
V_{ILC}	I/O V_{CC} Input LOW Voltage		-	-	0.15	-	0.15	V
V_{IHL}	I/O V_L Input HIGH Voltage		$V_L - 0.4$	-	-	$V_L - 0.4$	-	V
V_{ILL}	I/O V_L Input LOW Voltage		-	-	0.15	-	0.15	V
V_{IH}	Control Pin Input HIGH Voltage		$0.65 * V_L$	-	-	$0.65 * V_L$	-	V
V_{IL}	Control Pin Input LOW Voltage		-	-	$0.35 * V_L$	-	$0.35 * V_L$	V
V_{OHC}	I/O V_{CC} Output HIGH Voltage	I/O V_{CC} Source Current = 20 μ A	$0.8 * V_{CC}$	-	-	$0.8 * V_{CC}$	-	V
V_{OLC}	I/O V_{CC} Output LOW Voltage	I/O V_{CC} Sink Current = 1.0 mA, I/O $V_L \leq 0.15\text{ V}$	-	-	0.4	-	0.4	V
V_{OHL}	I/O V_L Output HIGH Voltage	I/O V_L Source Current = 20 μ A	$0.8 * V_L$	-	-	$0.8 * V_L$	-	V
V_{OLL}	I/O V_L Output LOW Voltage	I/O V_L Sink Current = 1.0 mA, I/O $V_{CC} \leq 0.15\text{ V}$	-	-	0.4	-	0.4	V
I_{QVCC}	V_{CC} Supply Current	I/O V_{CC} and I/O V_L Unconnected, $V_{EN} = V_L$	-	0.5	2.0	-	3.0	μ A
I_{QVL}	V_L Supply Current	I/O V_{CC} and I/O V_L Unconnected, $V_{EN} = V_L$	-	0.3	1.0	-	3.0	μ A
I_{TS-VCC}	V_{CC} Tristate Output Mode Supply Current	I/O V_{CC} and I/O V_L Unconnected, $V_{EN} = \text{GND}$	-	0.1	1.0	-	1.5	μ A
I_{TS-VL}	V_L Tristate Output Mode Supply Current	I/O V_{CC} and I/O V_L Unconnected, $V_{EN} = \text{GND}$	-	0.1	1.0	-	1.5	μ A
I_{OZ}	I/O Tristate Output Mode Leakage Current	$T_A = +25^\circ\text{C}$	-	0.1	1.0	-	1.0	μ A
R_{PU}	Pullup Resistor I/O V_L and V_{CC}	$T_A = +25^\circ\text{C}$	-	10	-	-	-	k Ω

Product parametric performance is indicated in the Electrical Characteristics for the listed test conditions, unless otherwise noted. Product performance may not be indicated by the Electrical Characteristics if operated under different conditions.

1. Typical values are for $V_{CC} = +2.8\text{ V}$, $V_L = +1.8\text{ V}$ and $T_A = +25^\circ\text{C}$.

2. All units are production tested at $T_A = +25^\circ\text{C}$. Limits over the operating temperature range are guaranteed by design.

NLSX4378A

TIMING CHARACTERISTICS – RAIL-TO-RAIL DRIVING CONFIGURATIONS

(I/O test circuit of Figures 2 and 3, $C_{LOAD} = 15 \text{ pF}$, driver output impedance $\leq 50 \Omega$, $R_{LOAD} = 1 \text{ M}\Omega$)

Symbol	Parameter	Test Conditions	-40°C to +85°C (Note 3)			-55°C to +125°C (Note 3)		Unit
			Min	Typ	Max	Min	Max	

$V_L = 1.65 \text{ V}$, $V_{CC} = 5.5 \text{ V}$

t_{RVCC}	I/O V_{CC} Risetime				15		15	ns
t_{FVCC}	I/O V_{CC} Falltime				30		30	ns
t_{RVL}	I/O V_L Risetime				30		30	ns
t_{FVL}	I/O V_L Falltime				10		10	ns
$t_{PDVL-VCC}$	Propagation Delay (Driving I/O V_L)				20		20	ns
$t_{PDVCC-VL}$	Propagation Delay (Driving I/O V_{CC})				20		20	ns
t_{SKEW}	Channel-to-Channel Skew				5		5	nS
MDR	Maximum Data Rate		24				24	Mb/s

$V_L = 1.8 \text{ V}$, $V_{CC} = 2.8 \text{ V}$

t_{RVCC}	I/O V_{CC} Risetime				15		15	ns
t_{FVCC}	I/O V_{CC} Falltime				15		15	ns
t_{RVL}	I/O V_L Risetime				25		25	ns
t_{FVL}	I/O V_L Falltime				10		10	ns
$t_{PDVL-VCC}$	Propagation Delay (Driving I/O V_L)				15		15	ns
$t_{PDVCC-VL}$	Propagation Delay (Driving I/O V_{CC})				15		15	ns
t_{SKEW}	Channel-to-Channel Skew				5		5	nS
MDR	Maximum Data Rate		24				24	Mb/s

$V_L = 2.5 \text{ V}$, $V_{CC} = 3.6 \text{ V}$

t_{RVCC}	I/O V_{CC} Risetime				15		15	ns
t_{FVCC}	I/O V_{CC} Falltime				10		10	ns
t_{RVL}	I/O V_L Risetime				15		15	ns
t_{FVL}	I/O V_L Falltime				10		10	ns
$t_{PDVL-VCC}$	Propagation Delay (Driving I/O V_L)				15		15	ns
$t_{PDVCC-VL}$	Propagation Delay (Driving I/O V_{CC})				15		15	ns
t_{SKEW}	Channel-to-Channel Skew				5		5	nS
MDR	Maximum Data Rate		24				24	Mb/s

$V_L = 2.8 \text{ V}$, $V_{CC} = 1.8 \text{ V}$

t_{RVCC}	I/O V_{CC} Risetime				25		25	ns
t_{FVCC}	I/O V_{CC} Falltime				10		10	ns
t_{RVL}	I/O V_L Risetime				15		15	ns
t_{FVL}	I/O V_L Falltime				15		15	ns
$t_{PDVL-VCC}$	Propagation Delay (Driving I/O V_L)				15		15	ns
$t_{PDVCC-VL}$	Propagation Delay (Driving I/O V_{CC})				15		15	ns
t_{SKEW}	Channel-to-Channel Skew				5		5	nS
MDR	Maximum Data Rate		24				24	Mb/s

3. Limits over the operating temperature range are guaranteed by design.

NLSX4378A

TIMING CHARACTERISTICS – RAIL-TO-RAIL DRIVING CONFIGURATIONS

(I/O test circuit of Figures 2 and 3, $C_{LOAD} = 15 \text{ pF}$, driver output impedance $\leq 50 \Omega$, $R_{LOAD} = 1 \text{ M}\Omega$)

Symbol	Parameter	Test Conditions	-40°C to +85°C (Note 3)			-55°C to +125°C (Note 3)		Unit
			Min	Typ	Max	Min	Max	
$V_L = 3.6 \text{ V}$, $V_{CC} = 2.5 \text{ V}$								
t_{RVCC}	I/O V_{CC} Risettime				15		15	ns
t_{FVCC}	I/O V_{CC} Falltime				10		10	ns
t_{RVL}	I/O V_L Risettime				15		15	ns
t_{FVL}	I/O V_L Falltime				10		10	ns
$t_{PDVL-VCC}$	Propagation Delay (Driving I/O V_L)				15		15	ns
$t_{PDVCC-VL}$	Propagation Delay (Driving I/O V_{CC})				15		15	ns
t_{SKEW}	Channel-to-Channel Skew				5		5	nS
MDR	Maximum Data Rate		24				24	Mb/s

$V_L = 5.5 \text{ V}$, $V_{CC} = 1.65 \text{ V}$

t_{RVCC}	I/O V_{CC} Risettime				30		30	ns
t_{FVCC}	I/O V_{CC} Falltime				10		10	ns
t_{RVL}	I/O V_L Risettime				15		15	ns
t_{FVL}	I/O V_L Falltime				30		30	ns
$t_{PDVL-VCC}$	Propagation Delay (Driving I/O V_L)				20		20	ns
$t_{PDVCC-VL}$	Propagation Delay (Driving I/O V_{CC})				20		20	ns
t_{SKEW}	Channel-to-Channel Skew				5		5	nS
MDR	Maximum Data Rate		24				24	Mb/s

3. Limits over the operating temperature range are guaranteed by design.

TIMING CHARACTERISTICS – OPEN DRAIN DRIVING CONFIGURATIONS

(I/O test circuit of Figures 4 and 5, $C_{LOAD} = 15 \text{ pF}$, driver output impedance $\leq 50 \Omega$, $R_{LOAD} = 1 \text{ M}\Omega$)

Symbol	Parameter	Test Conditions	-40°C to +85°C (Note 4)			-55°C to +125°C (Note 4)		Unit
			Min	Typ	Max	Min	Max	
$+1.65 \leq V_L$, $V_{CC} \leq +5.5 \text{ V}$								
t_{RVCC}	I/O V_{CC} Risettime				400		400	ns
t_{FVCC}	I/O V_{CC} Falltime				50		50	ns
t_{RVL}	I/O V_L Risettime				400		400	ns
t_{FVL}	I/O V_L Falltime				60		60	ns
$t_{PDVL-VCC}$	Propagation Delay (Driving I/O V_L)				1000		1000	ns
$t_{PDVCC-VL}$	Propagation Delay (Driving I/O V_{CC})				1000		1000	ns
t_{SKEW}	Channel-to-Channel Skew				50		50	nS
MDR	Maximum Data Rate		2				2	Mb/s

4. Limits over the operating temperature range are guaranteed by design.

NLSX4378A

TEST SETUPS

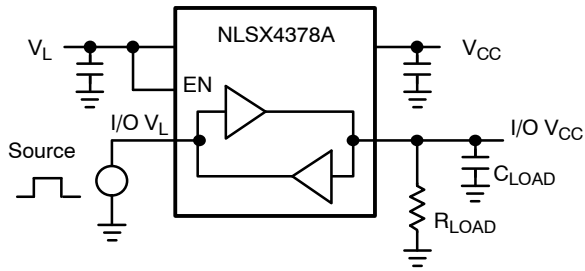

Figure 2. Rail-to-Rail Driving I/O V_L

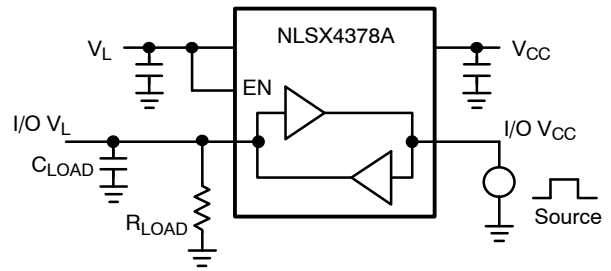

Figure 3. Rail-to-Rail Driving I/O V_{CC}

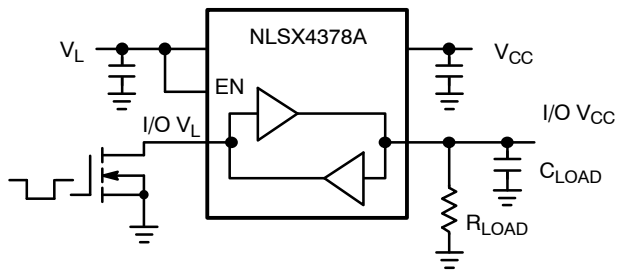

Figure 4. Open-Drain Driving I/O V_L

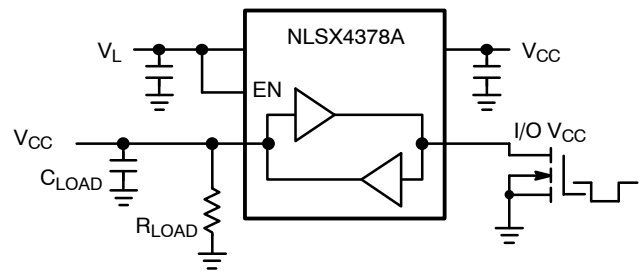

Figure 5. Open-Drain Driving I/O V_{CC}

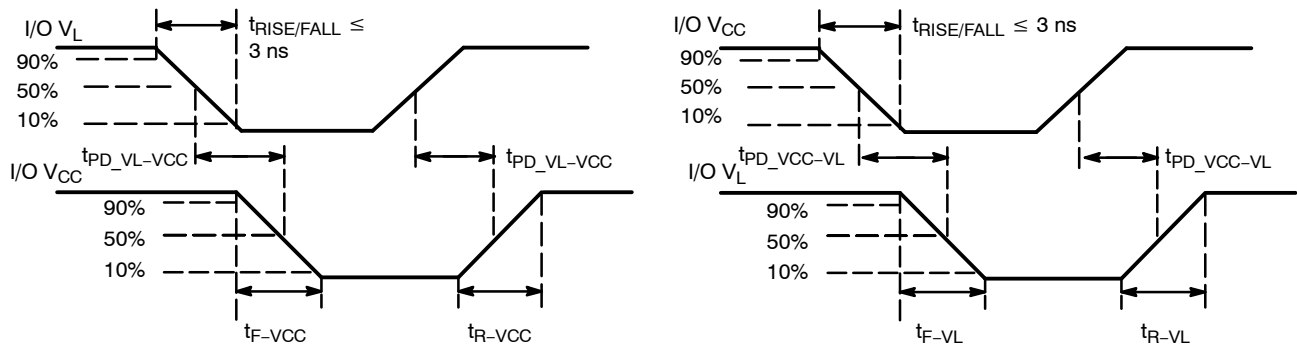

Figure 6. Definition of Timing Specification Parameters

NLSX4378A

APPLICATIONS INFORMATION

Level Translator Architecture

The NLSX4378A auto sense translator provides bi-directional voltage level shifting to transfer data in multiple supply voltage systems. This device has two supply voltages, V_L and V_{CC} , which set the logic levels on the input and output sides of the translator. When used to transfer data from the V_L to the V_{CC} ports, input signals referenced to the V_L supply are translated to output signals with a logic level matched to V_{CC} . In a similar manner, the V_{CC} to V_L translation shifts input signals with a logic level compatible to V_{CC} to an output signal matched to V_L .

The NLSX4378A consists of four bi-directional channels that independently determine the direction of the data flow without requiring a directional pin. The one-shot circuits are used to detect the rising input signals. In addition, the one shots decrease the rise time of the output signal for low-to-high transitions.

Each input/output pin has an internal 10 k Ω pull-up resistor. The magnitude of the pull-up resistors can be reduced by connecting external resistors in parallel to the internal 10 k Ω resistors.

Input Driver Requirements

The rise (t_R) and fall (t_F) timing parameters of the open drain outputs depend on the magnitude of the pull-up resistors. In addition, the propagation times (t_{PD}), skew (t_{SKEW}) and maximum data rate depend on the impedance of the device that is connected to the translator. The timing

parameters listed in the data sheet assume that the output impedance of the drivers connected to the translator is less than 50 Ω .

Enable Input (EN)

The NLSX4378A has an Enable pin (EN) that provides tri-state operation at the I/O pins. Driving the Enable pin to a low logic level minimizes the power consumption of the device and drives the I/O V_{CC} and I/O V_L pins to a high impedance state. Normal translation operation occurs when the EN pin is equal to a logic high signal. The EN pin is referenced to the V_L supply and has Overvoltage Tolerant (OVT) protection.

Power Supply Guidelines

During normal operation, supply voltage V_L can be greater than, less than or equal to V_{CC} . The sequencing of the power supplies will not damage the device during the power up operation.

For optimal performance, 0.01 μ F to 0.1 μ F decoupling capacitors should be used on the V_L and V_{CC} power supply pins. Ceramic capacitors are a good design choice to filter and bypass any noise signals on the voltage lines to the ground plane of the PCB. The noise immunity will be maximized by placing the capacitors as close as possible to the supply and ground pins, along with minimizing the PCB connection traces.

ORDERING INFORMATION

Device	Package	Shipping [†]
NLSX4378ABFCT1G	μ Bump12 (Backside Laminate Coating) (Pb-Free)	3000 / Tape & Reel

[†]For information on tape and reel specifications, including part orientation and tape sizes, please refer to our Tape and Reel Packaging Specifications Brochure, BRD8011/D.

MECHANICAL CASE OUTLINE

PACKAGE DIMENSIONS

ON Semiconductor®



12 PIN FLIP-CHIP, 2.02x1.54, 0.5P CASE 499AU-01 ISSUE O

DATE 19 MAR 2007



SCALE 4:1

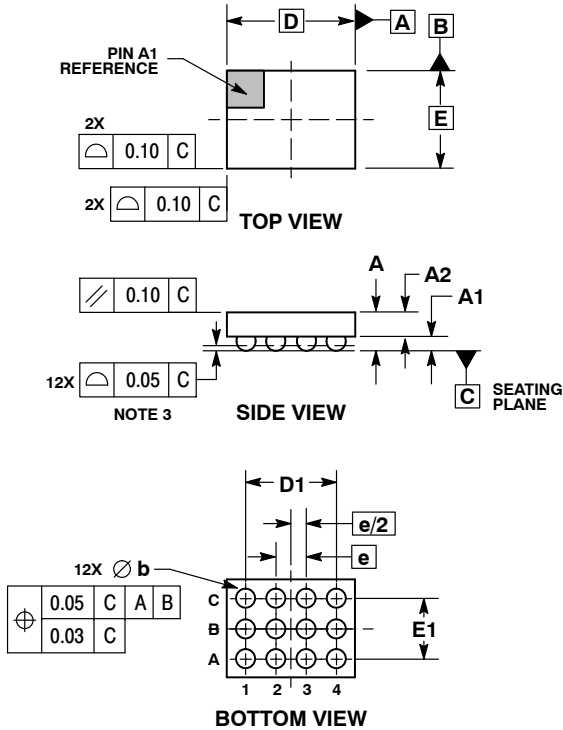

- NOTES:
1. DIMENSIONING AND TOLERANCING PER ASME Y14.5M, 1994.
 2. CONTROLLING DIMENSION: MILLIMETERS.
 3. COPLANARITY APPLIES TO SPHERICAL CROWNS OF SOLDER BALLS.

DIM	MILLIMETERS	
	MIN	MAX
A	---	0.66
A1	0.21	0.27
A2	0.33	0.39
b	0.29	0.34
D	2.02 BSC	
D1	1.50 BSC	
E	1.54 BSC	
E1	1.00 BSC	
e	0.50 BSC	

DOCUMENT NUMBER:	98AON24295D	Electronic versions are uncontrolled except when accessed directly from the Document Repository. Printed versions are uncontrolled except when stamped "CONTROLLED COPY" in red.
DESCRIPTION:	12 PIN FLIP-CHIP, 2.02 X 1.54, 0.5P	PAGE 1 OF 1

ON Semiconductor and are trademarks of Semiconductor Components Industries, LLC dba ON Semiconductor or its subsidiaries in the United States and/or other countries. ON Semiconductor reserves the right to make changes without further notice to any products herein. ON Semiconductor makes no warranty, representation or guarantee regarding the suitability of its products for any particular purpose, nor does ON Semiconductor assume any liability arising out of the application or use of any product or circuit, and specifically disclaims any and all liability, including without limitation special, consequential or incidental damages. ON Semiconductor does not convey any license under its patent rights nor the rights of others.

onsemi, **Onsemi**, and other names, marks, and brands are registered and/or common law trademarks of Semiconductor Components Industries, LLC dba "**onsemi**" or its affiliates and/or subsidiaries in the United States and/or other countries. **onsemi** owns the rights to a number of patents, trademarks, copyrights, trade secrets, and other intellectual property. A listing of **onsemi**'s product/patent coverage may be accessed at www.onsemi.com/site/pdf/Patent-Marking.pdf. **onsemi** reserves the right to make changes at any time to any products or information herein, without notice. The information herein is provided "as-is" and **onsemi** makes no warranty, representation or guarantee regarding the accuracy of the information, product features, availability, functionality, or suitability of its products for any particular purpose, nor does **onsemi** assume any liability arising out of the application or use of any product or circuit, and specifically disclaims any and all liability, including without limitation special, consequential or incidental damages. Buyer is responsible for its products and applications using **onsemi** products, including compliance with all laws, regulations and safety requirements or standards, regardless of any support or applications information provided by **onsemi**. "Typical" parameters which may be provided in **onsemi** data sheets and/or specifications can and do vary in different applications and actual performance may vary over time. All operating parameters, including "Typicals" must be validated for each customer application by customer's technical experts. **onsemi** does not convey any license under any of its intellectual property rights nor the rights of others. **onsemi** products are not designed, intended, or authorized for use as a critical component in life support systems or any FDA Class 3 medical devices or medical devices with a same or similar classification in a foreign jurisdiction or any devices intended for implantation in the human body. Should Buyer purchase or use **onsemi** products for any such unintended or unauthorized application, Buyer shall indemnify and hold **onsemi** and its officers, employees, subsidiaries, affiliates, and distributors harmless against all claims, costs, damages, and expenses, and reasonable attorney fees arising out of, directly or indirectly, any claim of personal injury or death associated with such unintended or unauthorized use, even if such claim alleges that **onsemi** was negligent regarding the design or manufacture of the part. **onsemi** is an Equal Opportunity/Affirmative Action Employer. This literature is subject to all applicable copyright laws and is not for resale in any manner.

ADDITIONAL INFORMATION

TECHNICAL PUBLICATIONS:

Technical Library: www.onsemi.com/design/resources/technical-documentation
onsemi Website: www.onsemi.com

ONLINE SUPPORT: www.onsemi.com/support

For additional information, please contact your local Sales Representative at www.onsemi.com/support/sales

