

6.6 kW Totem-Pole Demo Board User's Manual



EVBUM2784/D

ON Semiconductor®

www.onsemi.com

EVAL BOARD USER'S MANUAL

6.6 kW TOTEM POLE POWER STAGE

Device	Application	Input Voltage	Output Power	Topology	I/O Isolation
NCV57000DWR2G FAN7191MX-F085 NCV4274CST33T3G NCV2901DR2G NCV890100PDR2G NCV210RSQT2G NCV2003SN2T1G FSL336LRN NCL30059BDR2G NVHL060N090SC1 NVHL025N65S3 NVMFD5C680NLT1G ...	On Board EV Charger	90 – 264 Vac	6.6 kW	3CH Interleave Totem Pole	No

OTHER SPECIFICATION

Output Voltage	1.414 x Vin + 10 V – 405 Vdc
Typical Efficiency	97%
Input Current Limiting	32 A
Operating Temp. Range	-20 – 85°C
Cooling Method	Force Air or cooling
Dimension	254 x 198 x 70 mm + Heatsink + Controller Board

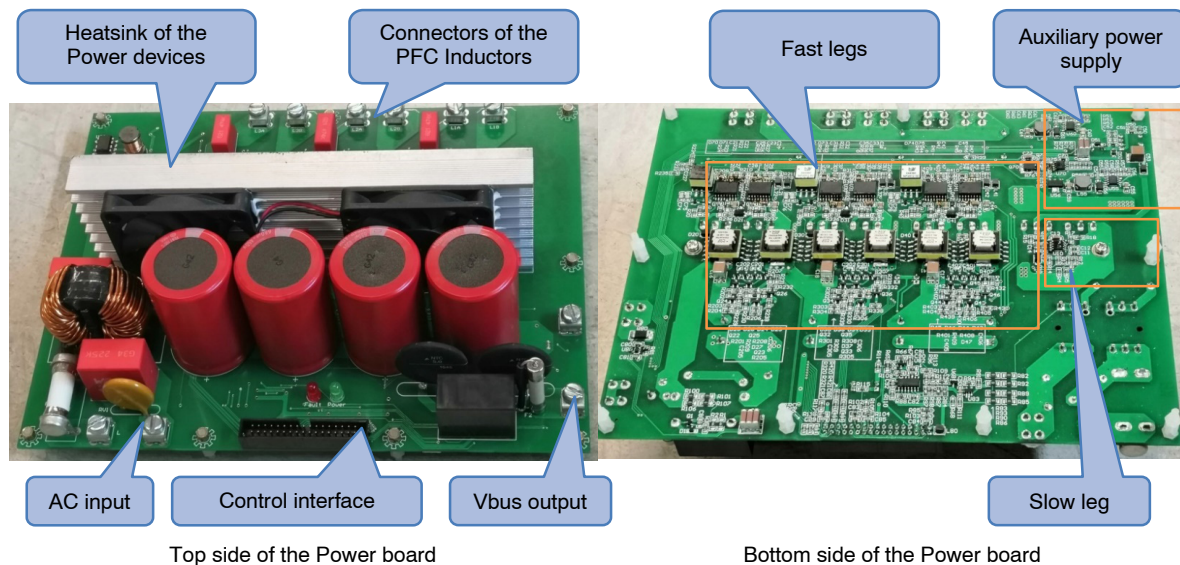

Figure 1. Photograph of Evaluation Board

EVBUM2784/D

SYSTEM OVERVIEW

Key Features

- 3 fast legs + 1 slow leg Interleave PFC and inverter to get high efficiency with low current ripple.
- Flexible control interface available to adapt different controller board
- Hardware protection of OCP and OVP.
- Onboard auxiliary power system to supply every circuits on the board and the control board. No outside DC source need.

Block Diagram of Hardware

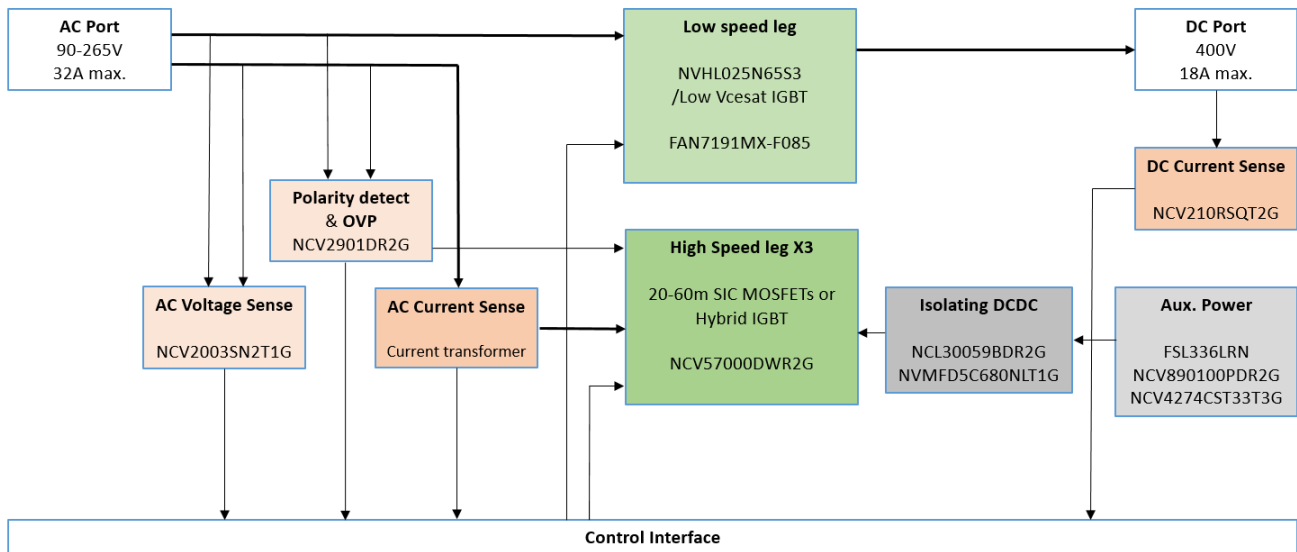

Figure 2. Block Diagram of Hardware

HARDWARE: SCHEMATICS AND CIRCUIT DESCRIPTION

Control Interface and Signals

Figure 3 shown the schematic of the control interface and some signals processing circuit which are related to the interface. A 34 pin dual row connector connect the power board and the control board. Table 1 is the signals on the connector.

For noise immunity reason, all of the analog signals are differential. The voltage range of the analog signals is 0–1 V_{p-p}. The voltage level of all digital signals is 3.3 V.

Table 1. SIGNALS OF THE CONTROL INTERFACE

Pin	Name	Type	Direction*	Description
1	GND	–	–	GND
2	POL	Digital	Output	AC Polarity. L > N POL = High; L < N POL = Low.
3	CS1+	Analog	Output	Positive inductor current of Fast CH1.
4	CS1–	Analog	Output	Negative inductor current of Fast CH1.
5	CS2+	Analog	Output	Positive inductor current of Fast CH2.
6	CS2–	Analog	Output	Negative inductor current of Fast CH2.
7	CS3+	Analog	Output	Positive inductor current of Fast CH3.
8	CS3–	Analog	Output	Negative inductor current of Fast CH3.
9	Vac+	Analog	Output	Positive AC voltage.
10	Vac–	Analog	Output	Negative AC voltage.
11	Vdc+	Analog	Output	Positive DC voltage.
12	Vdc–	Analog	Output	Negative DC voltage.
13	CSd+	Analog	Output	Positive current on DC terminal. 0.5 V = 0 A; 0 – 0.5 V: G to B; 0.5 V – 1 V: B to G.
14	CSd–	Analog	Output	Negative current on DC terminal. 0 V.
15	RDY	Digital	Output	Power Good signal of NCV57000. Active High.
16	FLT	Digital	I/O	Fault output. Open drain with 2.2 kΩ pull high resistor. Active Low.
17	GND	–	–	GND
18	REL	Digital	Input	Relay ON. Need to be pulled high and Source 2 mA+ after 2S power ON.
19	PWM1L	Digital	Input	Low site PWM signal of Fast CH1.
20	PWM1H	Digital	Input	High site PWM signal of Fast CH1.
21	PWM2L	Digital	Input	Low site PWM signal of Fast CH2.
22	PWM2H	Digital	Input	High site PWM signal of Fast CH2.
23	PWM3L	Digital	Input	Low site PWM signal of Fast CH3.
24	PWM3H	Digital	Input	High site PWM signal of Fast CH3.
25	PWMSL	Digital	Input	Low site PWM signal of Slow CH.
26	PWMSH	Digital	Input	High site PWM signal of Slow CH.
27	+15V	Power	Output	±1 V; 0 – 0.2 A
28	GND	–	–	GND
29	GND	–	–	GND
30	GND	–	–	GND
31	GND	–	–	GND
32	GND	–	–	GND
33	+5V	Power	Output	±0.25 V; 0 – 0.5 A
34	+5V	Power	Output	±0.25 V; 0 – 0.5 A

*The signal Direction Input/output is based on the power board.

EVBUM2784/D

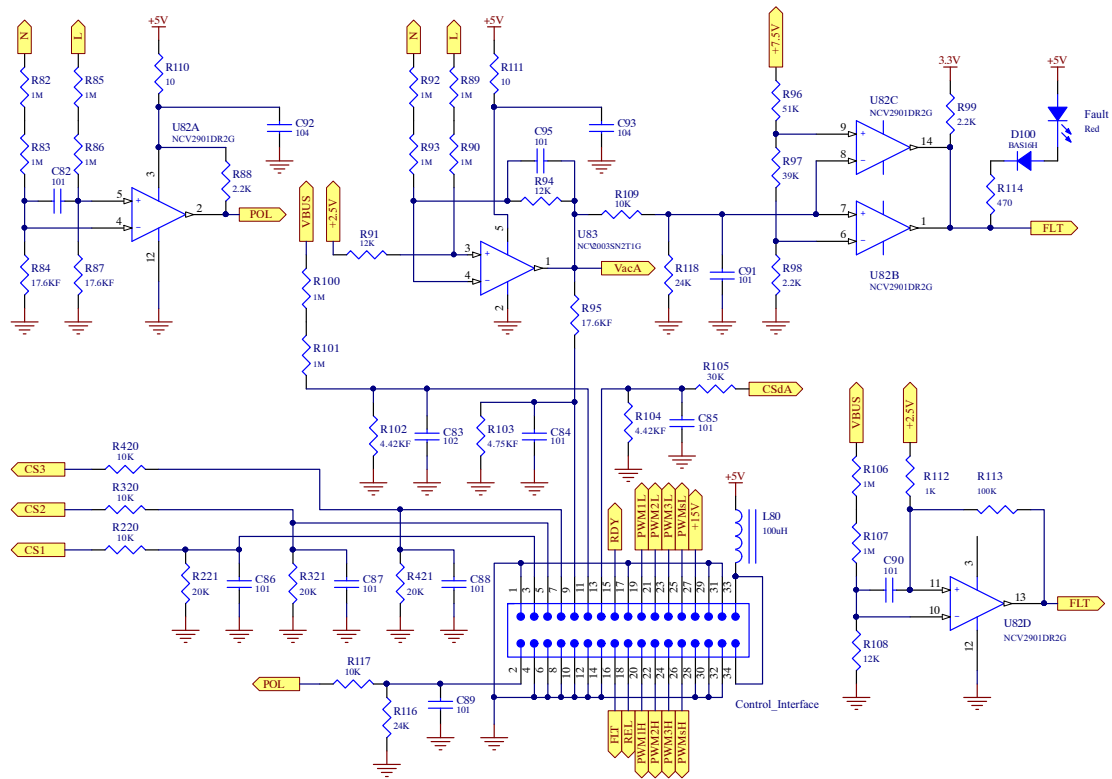

Figure 3. Schematic of the Control Interface

POL

This is a logical signal to identify the polarity of the AC input. During the positive half cycle ($V_L > V_N$), POL = High; during the negative half cycle, POL = Low. The signal generated by the comparator A of U82. The voltage level is 5 V on the output pin of the comparator. It is delivered to the inductor current sensing circuits for the polarity converting. While deliver to the Pin 2 of interface connector, the voltage level was divided to 3.3 V by the R117 and R116.

Vac

This is an analog signal which scale down the voltage on the AC terminal and shift to 0 V+ for easy processing. It was done by a rail to rail operational amplifier U83. The voltage ratio between VacA and AC terminal determined by the resistance of R91 and R94 vs (R89 + R90) and (R92 + R93). So $VacA = 2.5 V + 0.006 V_{AC}$. The VacA is send to comparator B and C of U82 for the Vac OVP on the inverter mode and divided by 5 then send to the interface connector.

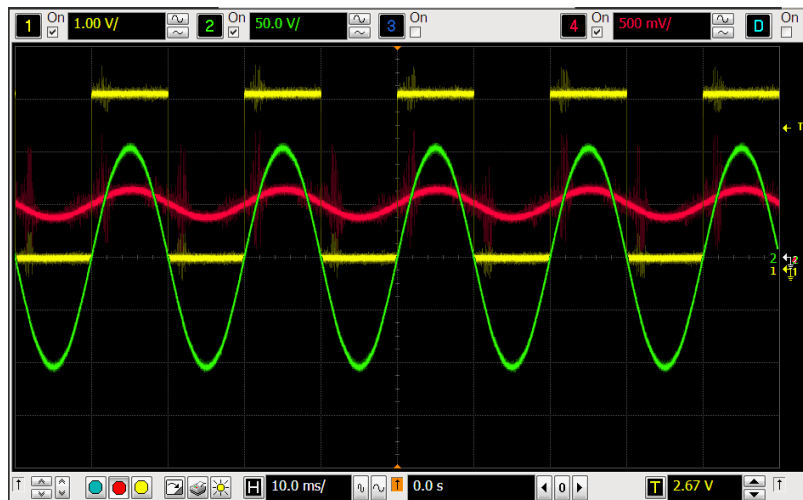

Figure 4. Vin (Green), Vin Sampled Signal (Red) and POL (Yellow)

Vdc

This is an analog signal which scale down the voltage on the DC terminal. The DC voltage divided by the resistors of R100, R101 and R102. $V_{dc} = 1 \text{ V}$ means the voltage on DC terminal = 453.5 V.

FLT

This signal act as the Faults alert and protection execution. All of the output pin which connected to this node are open drain and it was pull high to 3.3 V by R99. If FLT is pulled

low, it means at least 1 of the following conditions matched: (1) $V_{bus} > 415 \text{ V}$ (Implement by comparator D of U82); (2) $|V_{ac}| > 383 \text{ V}$ (Implement by comparator B and C of U82); (3) Inductor current in any channel $> 30 \text{ A}$ (Will discrete in following content); (4) Pull low by the control board. Once the FLT is pull low, the PWM signal on any gate of fast bridge MOSFET will be mute.

PWMxH/L

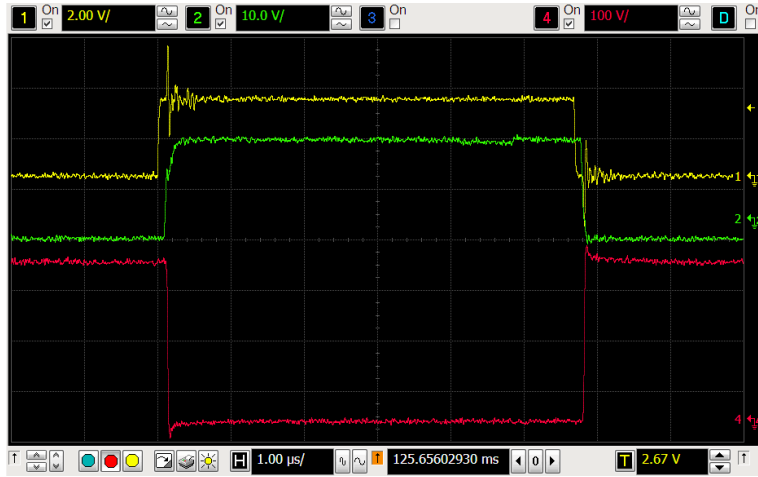

Figure 5. PWM Driving Signal (Yellow), Vgs of Switching Device (Green) and Vds of Switching Device (Red)

EMI Filter and the Slow Leg

Figure 6 shown the schematic of the EMI filter on AC terminal and the low speed switching. The half bridge switch devices Q10, Q11 is turned on/off complementary in 50/60 Hz. Due to the low switching speed, the conducting loss domain instead of the switching loss. So low $R_{ds(on)}$

MOSFET and low V_{sat} IGBT is the choice. The automotive qualified 8 pin half bridge driver FAN7191MX-F085 is used to drive the Q10 and Q11. What we need to think over here is the enough capacitance of the bootstrap capacitor and avoid to use the electrical capacitor for lift time reason. So we parallel 2 pcs MLCC C14 and C15.

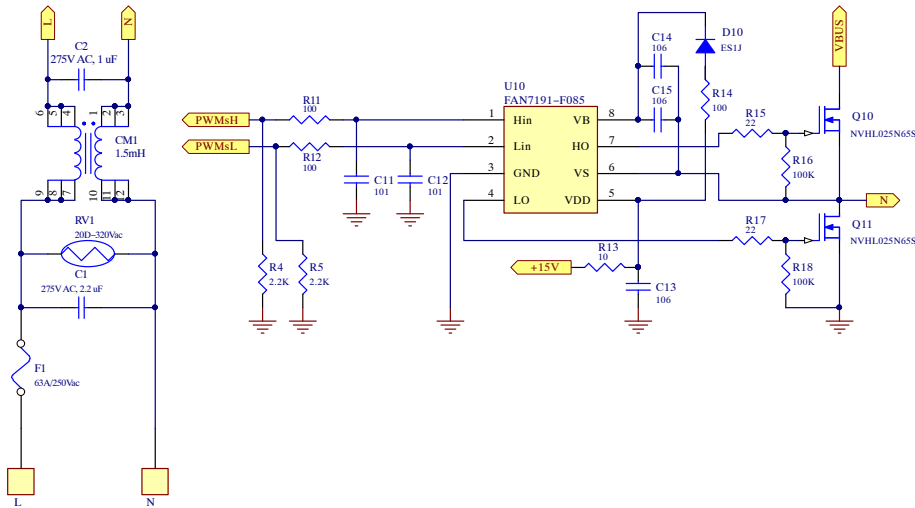

Figure 6. Schematic of the EMI Filter and Low Speed Switching Leg

EVBUM2784/D

Fast Legs, Current Sense and Hardware OCP

For better efficiency and thermal management, we separate the fast leg to 3 channels. The 3 fast legs switch in

120° phase shift each other. Figure 7, 8 and 9 showed the schematics.

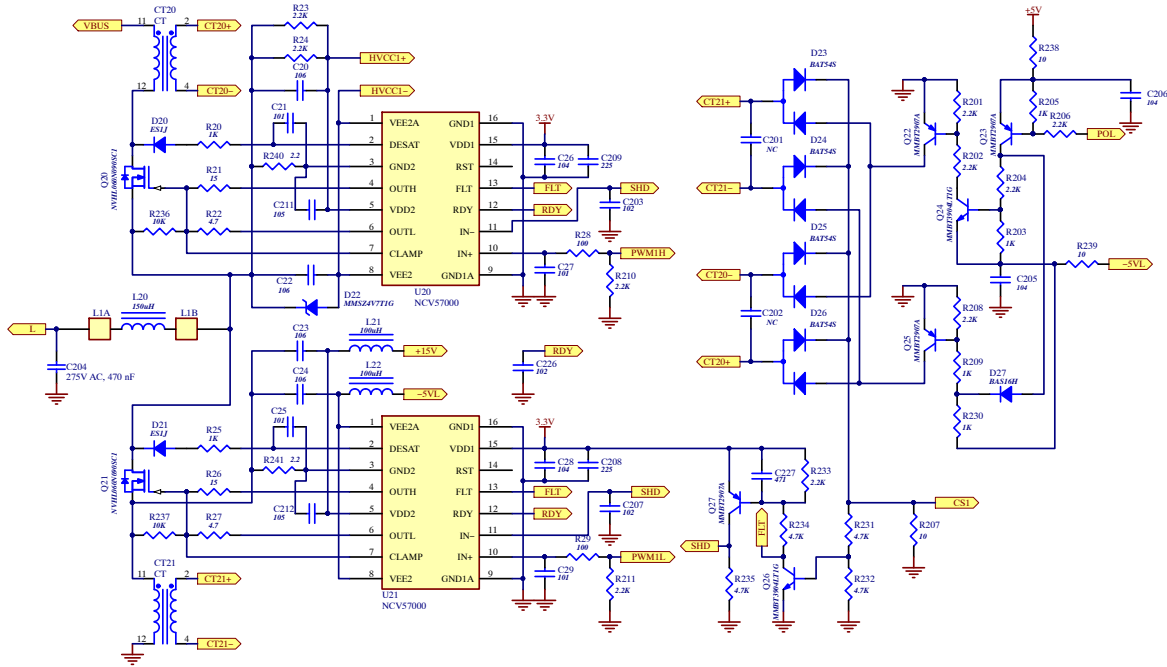

Figure 7. Schematic of the Fast Switching Channel 1

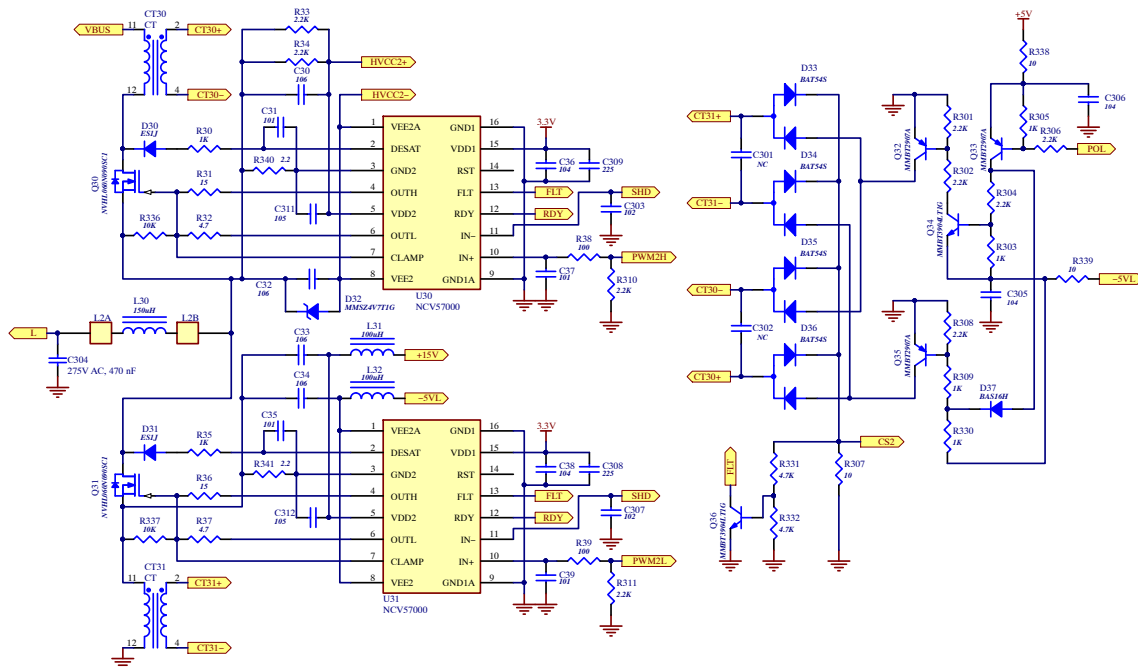

Figure 8. Schematic of the Fast Switching Channel 2

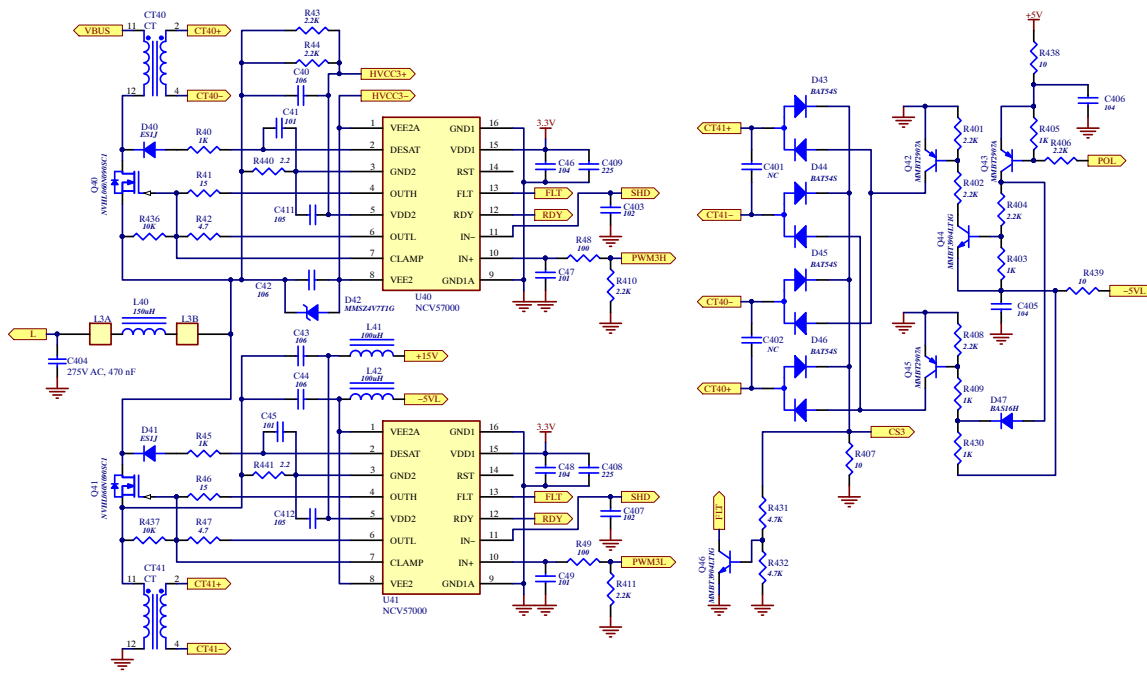

Figure 9. Schematic of the Fast Switching Channel 3

The switching devices of the lower legs (Q21, Q31, Q41) and higher legs (Q20, Q30, Q40) are driven respectively by 6 pcs galvanic isolation gate drivers NCV57000. You can find the detail information on the web site: <https://www.onsemi.com/products/discretes-drivers/gate-drivers/ncv57000>. The IN+ pins accept the PWM signals to switch on/off the MOSFETs. All of the IN- pins are tied together to execute the protection. All of the FLT pins connect to the FLT node to report the DESAT fault to the control board and pull low the gate at same time. All of the RDY pins are tied together and send ready message to the control board. The Vcc and Vee of the lower legs are power from the auxiliary +15 V and -5 V power. Both was de-coupled by the 100 μH chip inductor. These inductors are important because the current transformers are inserted between the GND2 and the system GND. The Vcc and Vee of the higher legs are power from the isolated DCDC converter. We will describe the on the following content.

The inductor current of the fast legs are sensed by current transformers CT20, CT21, CT30, CT31, CT40 and CT41; and the peripheral circuits. Let's describe the operating by the example of channel 3. On the positive half cycle of AC in (L > N), the POL = 1. Q45 is turned on and Q42 is off. When the PWM3L high, the Q41 is on. The current of L40 flow into pin 11 of CT41 and out of pin 12. The inducted current come out from pin2 of CT41 and go through upper diode of D43, then flow through the R407. The current

generate a positive voltage drop on the R407 and go on flow through the path: Q45E ⇒ Q45C ⇒ Lower diode of D44 ⇒ Pin4 of CT41. When the PWM3L turn off and no matter the PWM3H is on or off, the free-wheel current will flow through the Q40 and CT40 from pin 12 to pin 11. The inducted current come out from pin 4 of CT40 and go through upper diode of D45, then flow through the R407. The current also generate a positive voltage drop on the R407 and go on flow through the path: Q45E ⇒ Q45C ⇒ Lower diode of D46 ⇒ Pin 2 of CT40. We can see, the CT40 and CT41 take action alternately in one PWM cycle to generate a whole current waveform on R407. On the half cycle which the CT don't work, they reset in magnetic to realize the Volt-second balance. On the negative half cycle of AC in (L < N), the POL = 0. Q42 is turned on and Q45 is off. A positive waveform can also generate on the R407. The processing is same.

The turn ratio of the CTs is 1:200. So the voltage drop on the R207, R307 and R407 equal to the inductor current times 10 Ω / 200. The Q26, Q36 and Q46 act as the hardware over current protection in draft. For example, if the inductor current channel 3 reach to 28 A, the voltage on the R407 will be 1.4 V. The Q46 will turn on to pull low the FLT. All of the IN- of NCV57000 will be pull high by Q27, the Gate of all fast legs will be pull low. The inductor current stop to increase.

Auxiliary Power Supply

We have no isolation requirement between the power source (VBUS) and most of the loads of the Auxiliary power. So we use the HV Buck switcher U50 to generate the +15 V. And use 2 LV DCDC regulator U55 and U60 to

generate the +5 V and -5 V separately. Then generate the +3.3 V with LDO U56 from +5 V. This way make the circuit simple and avoided the cross regulation between each voltage rail. Figure 10 showed the schematics.

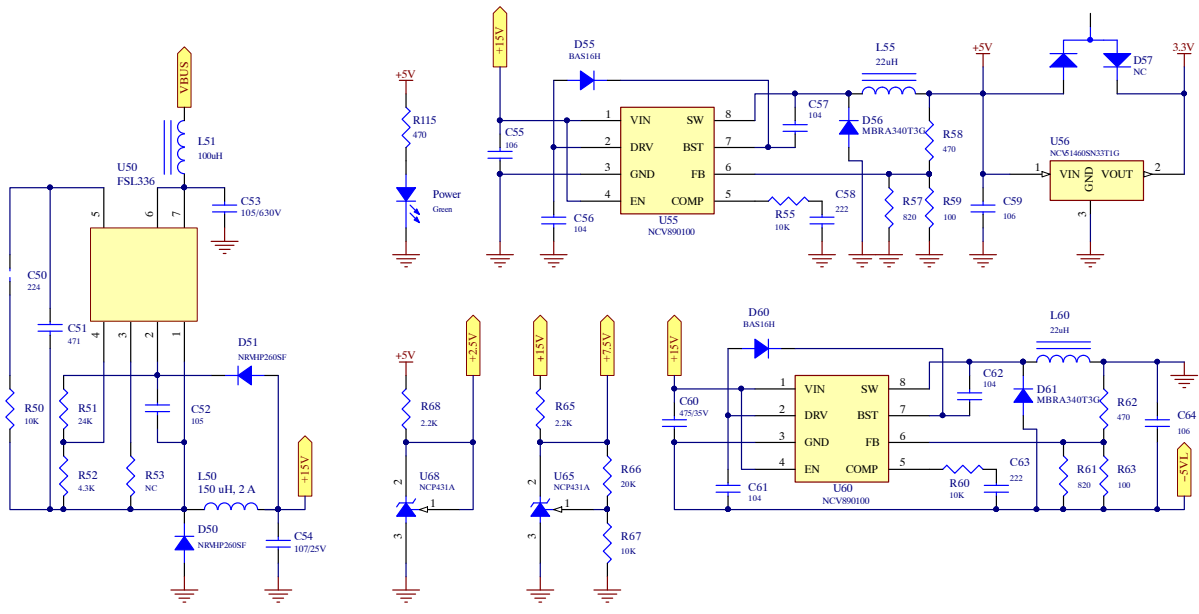

Figure 10. Schematic of the Auxiliary Power Supply

The voltage reference of +2.5 V and +7.5 V are regulated by the shut reference chip U68 and U65. All of these devices can found on the website of <https://www.onsemi.com/products>. The rich resources include data sheet, application note and evaluation board document can help you achieve the successful design.

Beside of above voltage rails, we also need 3 pairs of +15 V and -5 V floating voltage on the Vcc and Vee of the high side of the fast legs. These voltages are powered by the circuits shown in Figure 9. In general, it is three channels, open loop, push-pull, series resonate DCDC converter. U70

generates the near 50% duty-cycle, alternate on/off, 133 kHz driving signals on pin 5 and pin 7. Q70 and T70 – T72 forms 3 channels parallel push-pull converter which powered by +15 V. The leakage inductance of the transformer T70 – T72 is around 15.2 μH. Together with the capacitors C74 – C79, the resonate frequency is same with the push-pull signal. Both of the Q70 and D70 – D70 operate on soft switching. The gain of the converter keep stable. +20 V voltages output after the full bridge rectifiers. The Zener diode D42 and R43, R44 on fast leg 3 separate the +20 V to +15 V and -5 V. The fast leg 1 and 2 is same.

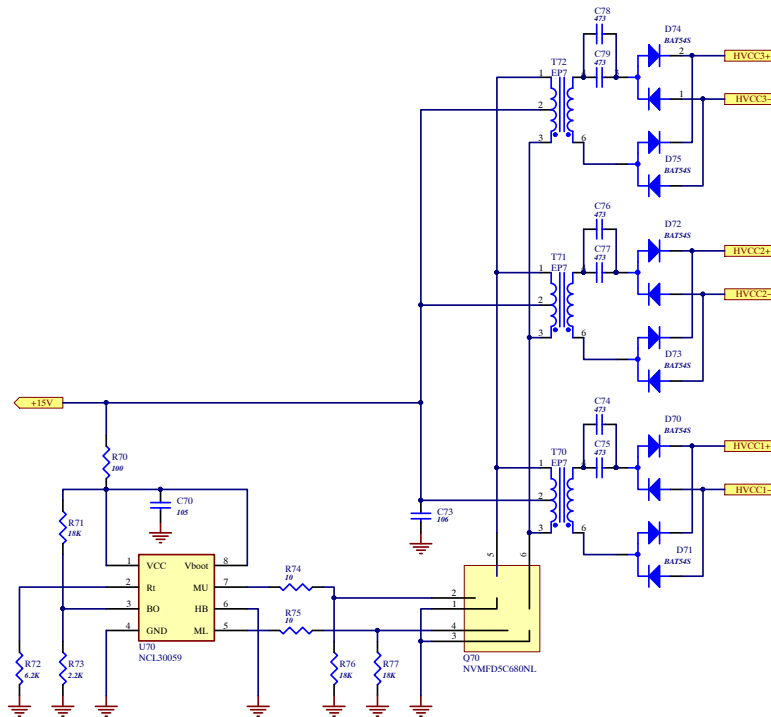

Figure 11. Schematic of the Isolating Auxiliary Power

Inrush Current Limit and DC Terminal Current Sense

In Figure 12, the RT1 and RT2 limit the current which charging the bus capacitors C3 – C6 whatever the converter or inverter mode. After the capacitors are fully charged, the Q1 receive the turn on signal of REL to turn on the RL1 and short the RL1 and RL2.

The current of the DC terminal is sensed by R80 and amplified by the automotive qualified current amplifier U80. The detail information of U80 can be found on <https://www.onsemi.com/products/amplifiers-comparator/s/current-sense-amplifiers/ncs210r>.

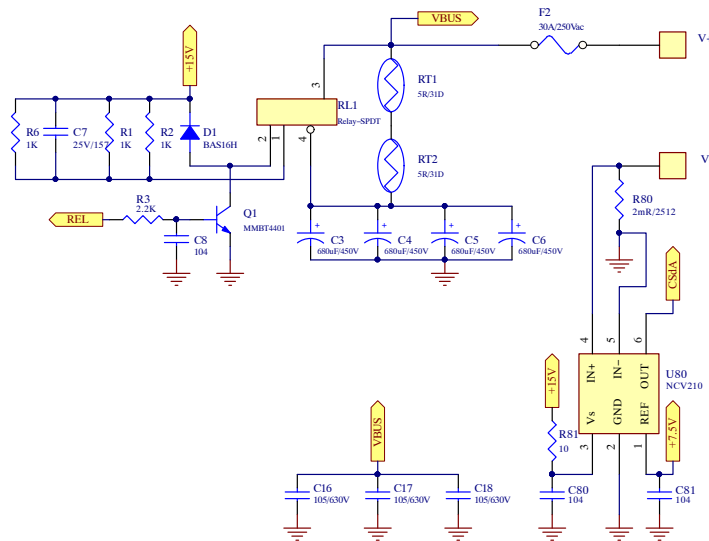

Figure 12. Schematic of the Inrush Current Limit and DC Terminal Current Sense

SOFTWARE AND TEST RESULTS

Software System Overview

The whole software system consists of 4 modules: Processing system, GPIO device module, ADC sampling module and PWM driving module. Processing system runs control algorithm and deals with all signal processing, timer, calling interrupt and peripheral driving.

GPIO module receives signals, such as POL and FLT, and transmits REL level to the board. POL is mainly used in zero crossing detection section to drive complementary PWM, and FLT stands for abnormal condition happening, such as

OVP, OCP and Mosfet driving issues. Processing system will send REL to close the relay on the board in power-on process.

PWM module will generate complementary and exchangeable outputs between high-side and low-side for driving Mosfet, and its function includes providing adjustable duty cycle and dead-band timeslot, offering common time-base signal for 3 single channel PWMs, and generating trigger signal for ADC sampling.

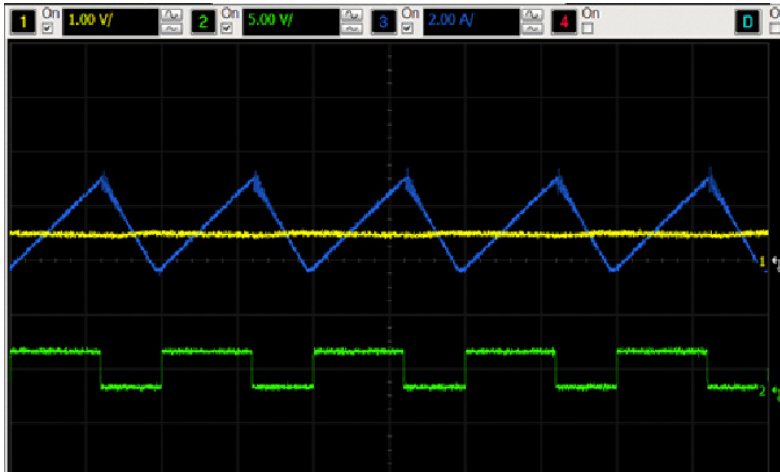

Figure 13. Exact Sampling Instant of ADC in CCM Mode

As the application utilizes the CCM algorithm, the input current sampling instant of ADC must be exactly located in the middle of switching device conduction timeslot, then the sampling value can be regarded as accurate average inductor current. To achieve the above sampling mechanism, the PWM module must send the sampling trigger to ADC, informing ADC of sampling instant. In the above figure, the green curve PWM stands for conduction period, while blue curve is triangular inductor current. The yellow one

representing sampled input current shows that ADC has accurately accomplished sampling task

Software Control Algorithm

PFC Finite State Machine

The finite state machine (FSM) of PFC is called every 40 μ s in timer interrupt. It manages the board to switch states and deal with some emergency conditions. The whole picture of FSM can be shown below:

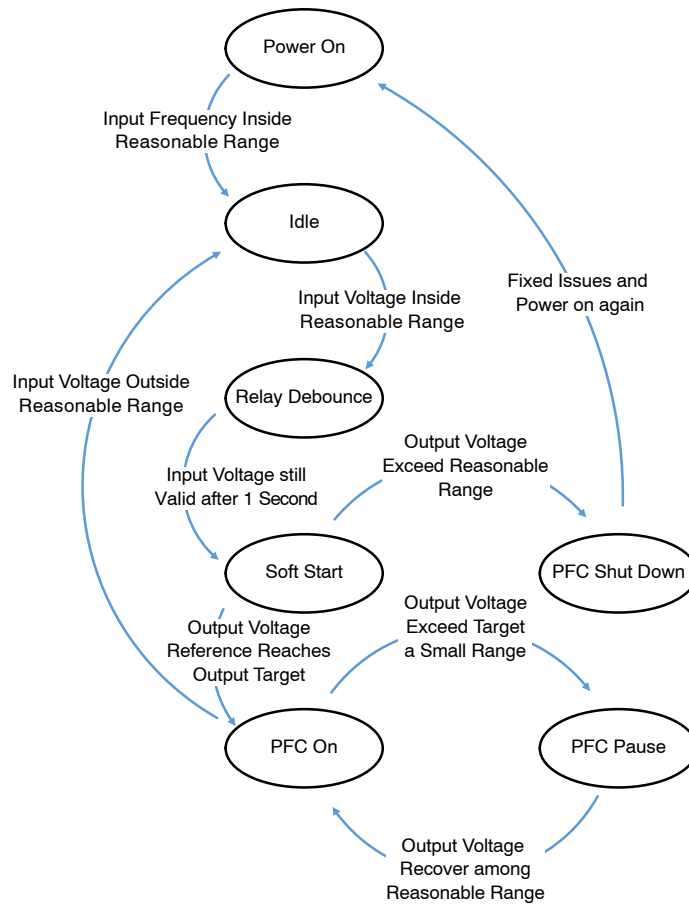

Figure 14. FSM Switching Flow Diagram

The effective input voltage magnitude ranges from 90V to 264 V. When the input voltage (V_{in}) increases to 90 V, a CLOSE command is sent to relay to bypass the resistor. Then the board stays in relay debounce state for 1 second to allow the bus voltage (V_{bus}) becomes stable and flat. Then the board will raise its output voltage in a ramp rather than a step change, until it reaches the reference V_{bus} value. If some hardware issues occur or some firmware parameters are not set correctly, the V_{bus} will jump to a high voltage which exceeds the target by 10%, then the board will enter shut down state and leave issues to be solved and power on again. In case of no failure event, the board will come into PFC on mode where the board stays in and waits for some emergency condition happens. The board will implement

the hardware protection against overvoltage (OV) and undervoltage. When encountering OV, the board will turn off the power switches and move to pause state until V_{bus} decreases to normal level. If V_{in} falls below 90 V, board will recover to idle state and repeat the above process.

Double Closed Loop Control

Once the board enters into soft start and PFC on states, the MCU will run double closed loop control algorithm: inner current loop and outer voltage loop. Inner current loop guarantees same frequency and zero phase error between input current and input voltage, while outer voltage keeps V_{bus} fixed at reference value no matter what value V_{in} is and how heavy the load is.

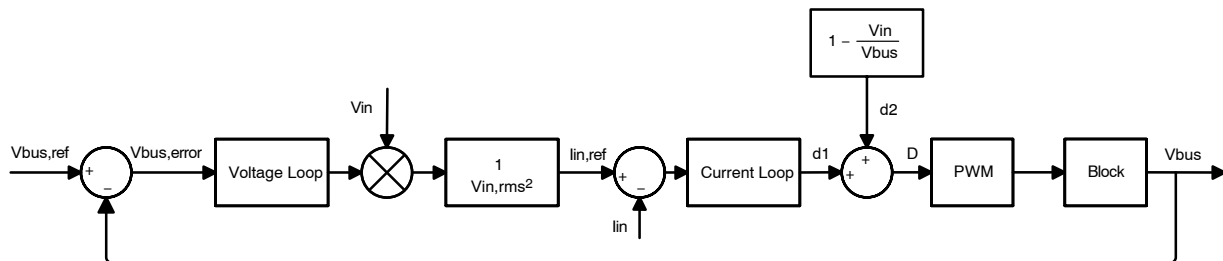

Figure 15. Voltage Loop and Current Loop Control Model

To perform the control algorithm, 5 signal quantities need to be sampled: 3 single phase input current I_{in} , grid input voltage V_{in} and output bus voltage V_{bus} .

The PI controller is used to regulate the current loop (CL) and it's important to keep the enough current loop bandwidth and high steady gain, which will ensure it can react to slight V_{in} change and improve the power factor. To design the parameters of PI compensator, the current loop model must be constructed.

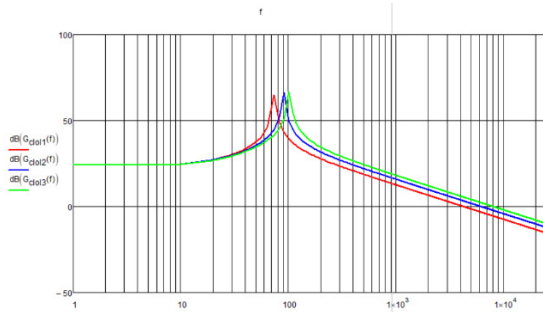
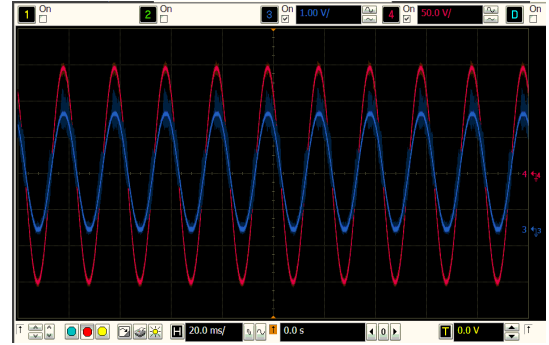

Figure 16. Frequency Response of Current Loop Control Model

The voltage loop (VL) is also regulated by PI compensator. The voltage loop output is multiplied by V_{in} which provides the phase reference, then divided by square of V_{in} RMS value. The result is then used as input current reference and processed by CL. The above 2 V_{in} RMS values in the denominator play different roles: one ensures VL result to own per unit value after it is given phase reference, the other keeps input current reference inversely proportional to input voltage magnitude. In the end, this operation guarantees that a fixed input power is injected to the board and hence owns a stable output power.

Besides double closed loop control, the feed-forward control is also used in duty cycle calculation. The instant value of V_{in} and V_{bus} will contribute to duty cycle change, which will significantly increase the response speed and relieve the computing load of CL.

Zero Crossing Detection



Red curve: input voltage; Blue curve: sine value of input phase generated by PLL

Figure 17. V_{in} and its Corresponding Phase

Phase Lock Loop

Phase Lock Loop (PLL) has been used in zero crossing detection, providing MCU with accurate phase of input voltage regardless of input voltage magnitude. Then MCU will find the switch instant of low-frequency switches. If adopting fixed comparison value as low-frequency switch instant, the dead-band timeslot will change as input voltage magnitude fluctuates. Low-frequency Mosfets may be short-circuited because of small dead-band timeslot. Additionally, PLL adoption can minimize dead-band between low-frequency switches by narrowing the zero-crossing comparison values. In the end, the efficiency will improve significantly.

Test Results

Waveforms of PFC stage. Blue: Input Voltage; Yellow: Input Current; Red: Output voltage.

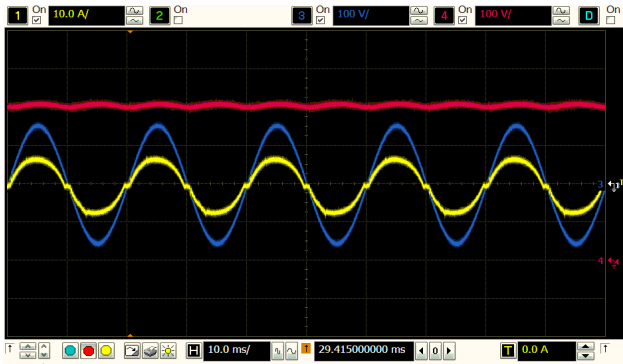

Figure 18. Vin 90 V, Pin = 660 W

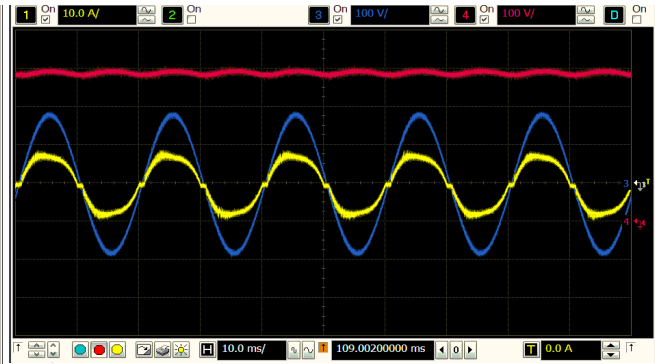

Figure 19. Vin 120 V, Pin = 660 W



Figure 20. Vin 90 V, Pin = 1.65 kW



Figure 21. Vin 120 V, Pin = 1.65 kW

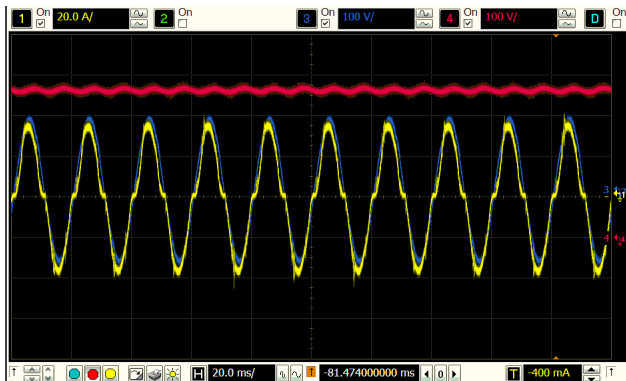

Figure 22. Vin 120 V, Pin = 3.3 kW

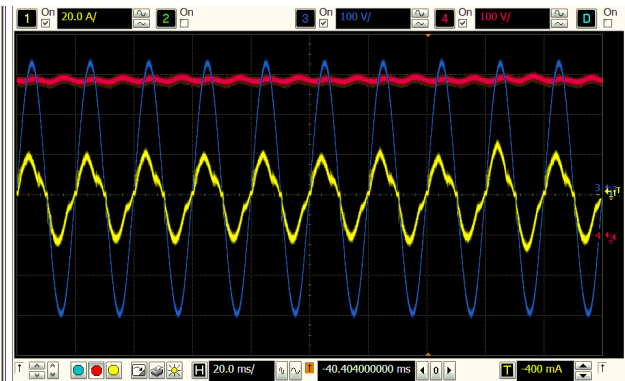

Figure 23. Vin 220 V, Pin = 3.3 kW



Figure 24. Vin 220 V, Pin = 4.95 kW



Figure 25. Vin 220 V, Pin = 6.6 kW

Table of PF values.

Table 2. TABLE OF PF VALUES

Output Power (% of Full Load)	Power Factor (Vin = 110 V)	Power Factor (Vin = 220 V)
10%	0.992	0.987
25%	0.977	0.973
50%	0.982	0.958
75%	–	0.966
100%	–	0.952

Curve of efficiency.

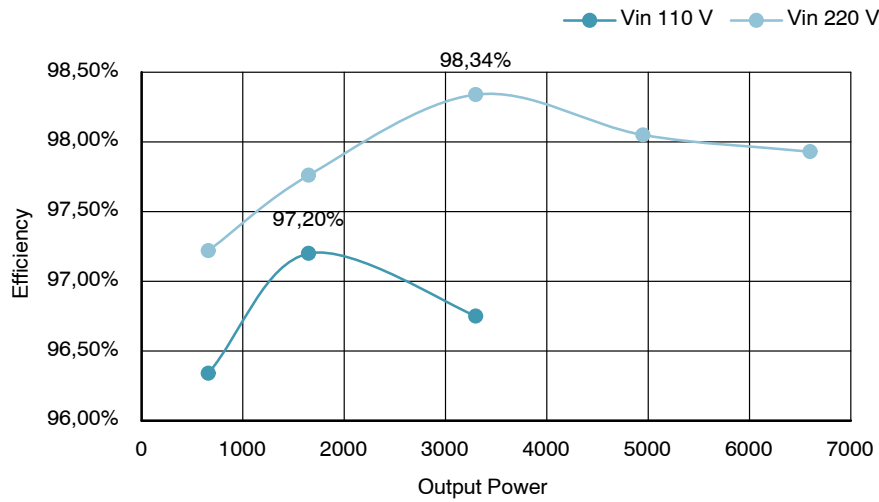
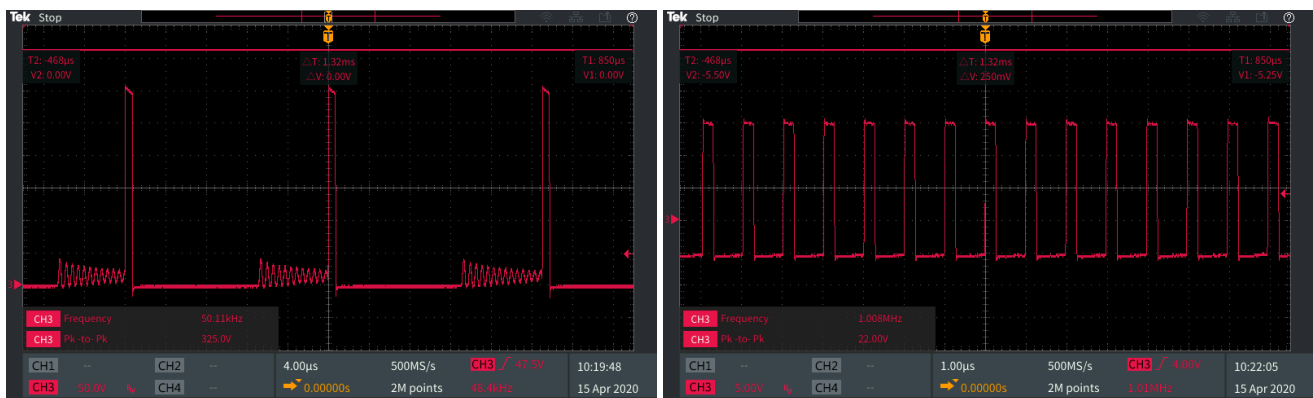

Figure 26. Curve of Efficiency

Waveforms of Auxiliary power.

Switching waveform of +15 V Buck converter (U50) and -5 V Buck-Boost converter (U60).



CH3 (Red): Voltage of U50 Pin 1

CH3 (Red): Voltage of U60 Pin 8

Figure 27. Switching Waveform of +15 V Buck Converter (U50) and -5 V Buck-Boost Converter (U60)

EVBUM2784/D

Switching waveforms of isolating DCDC converter (U70).

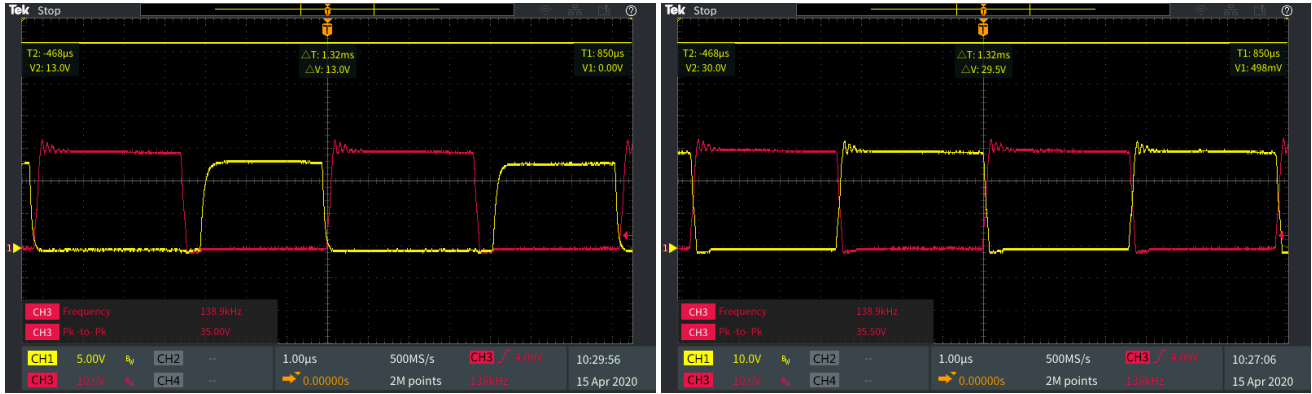

CH1 (Yellow): Voltage of Q70 Gate (pin 2);
CH3 (Red): Voltage of Q70 Drain (pin 5).

CH1 (Yellow): Voltage of Q70 Drain (pin 2);
CH3 (Red): Voltage of Q70 another Drain (pin 5).

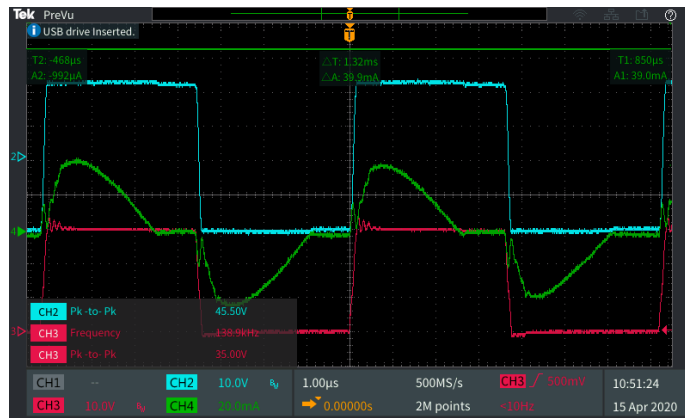

CH2 (Cyan): Voltage on secondary winding of T70 (Pin4-6);
CH3 (Red): Voltage of Q70 Drain (pin 6).
CH4 (Green): Current of secondary winding of T70.

Figure 28. Switching Waveforms of Isolating DCDC Converter (U70)

MEGNATICS Design Data Sheet

PFC Inductors: L20, L30, L40

Locate outside of the PCB. Two supplier's parts are available.



Magsonder Innovation (Shanghai) Co., Ltd

墨尚电子技术(上海)有限公司

P/N:HTR-253550-181M

Dimension (mm, ±0.5mm tol.)

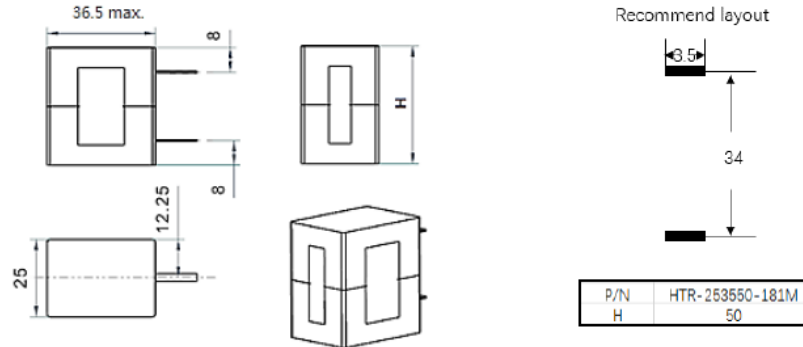

Electrical Characteristics at 25°C

HTR: Dimension		L ₀ (uH)	R _{dc} (mΩ)		Isat(A)
Overall size (mm)	P/N	±20%	TYP.	MAX.	TYP.
25*35*50	HTR-253550-181M	180	18.5	20.0	26A for 45% rolloff

Typical DC-bias curve

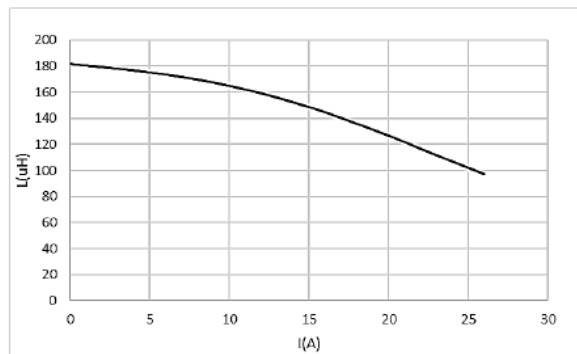

Test instruments & Test condition

Items	Testing Condition	Testing Point	Specification
Inductance	100KHz, 1V HP4284 or Equivalent	L: Terminal - Terminal	as L-I Curve
Dielectric Strength	LK7122 or Equivalent	Coil-Core/Housing	2.5KV AC, 50Hz, 1Min. < 2mA
Insulation Resistance	LK7122 or Equivalent	Coil-Core/Housing	> 100MΩ, 0.5KV, DC
Operating Temperature	Class F Insulation, -25 °C ~ 155 °C		
Storage Temperature	-25 °C ~ 75 °C		
Dimension (mm)	See Spec. detail		

Figure 29.

**Proposal of Common Mode Choke for
ARLDC805665C141N3B**

Approve By	Checked By	Prepared By
Jinbo Cai	Xiang Liu	Minglei Yang
2019/7/15	2019/7/15	2019/7/15

Note: This is a preliminary proposal and the final product P/N, Structure, Shape and Dimensions, Electrical Characteristics may be changed. You are requested to confirm and approve our spec.

1. Structure and Material

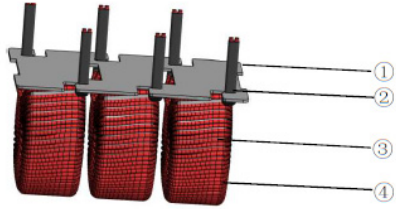

No.	Part Name	Material Name
①	Base	Phenolic
②	Glue	EPOXY
③	Wire	Polyester Enamelled Copper Wire (Φ1.6mm*2)
④	Core	Nanodust KAM158060A-AH

2. Shape and Dimensions (unit:mm)

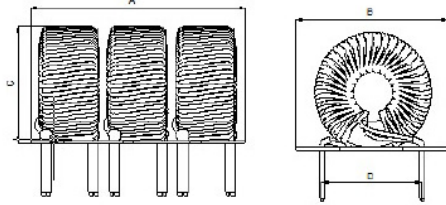

Note : For RoHS Compliant Products:

- 1.Solder : Sn /Ag /Cu .
- 2.Marking Code:B1905001 Sunlord Code.
- 3.Date Code: ** ** ****

- ① Year
- ② Week
- ③ Trace Code

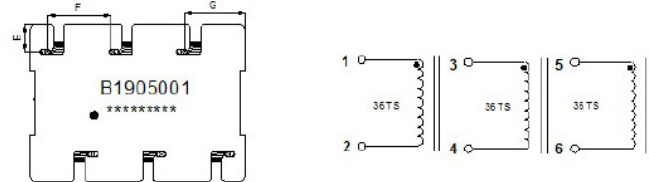

Shape and Dimensions

Item	A	B	C	D	E	F	G
Sunlord Spec.	80.0Max	56.0Max	65.0Max	38.0Ref	10.0Ref	24.0Ref	23.0Ref

3. Electrical Characteristics (Operating Temperature: - 40℃ to + 125℃)

Sunlord P/N:ARLDC805665C141N3B

Parameters	Inductance			DCR			Inductance(26A)			HI-POT
Unit	uH Min			mΩ Max			uH Min			-
TEST TERMINAL	Pin(1-2)	Pin(3-4)	Pin(5-6)	Pin(1-2)	Pin(3-4)	Pin(5-6)	Pin(1-2)	Pin(3-4)	Pin(5-6)	Winding to Core
Sunlord Design	140.0	140.0	140.0	17.0	17.0	17.0	85.0	85.0	85.0	1500Vac/50Hz/ 2s/5mA
Test Condition	Measured at 100KHz,1V,25°C			Measured at 25°C			Measured at 25°C			Measured at 25°C

Note: • Resistance to reflow soldering heat in accordance with JEDEC J-STD-020D with 245 °C for 10 seconds
• MLS level 1 • RoHS compatible

Version: 02

Figure 30.

Isolate DCDC Transformer: T70, T71, T72

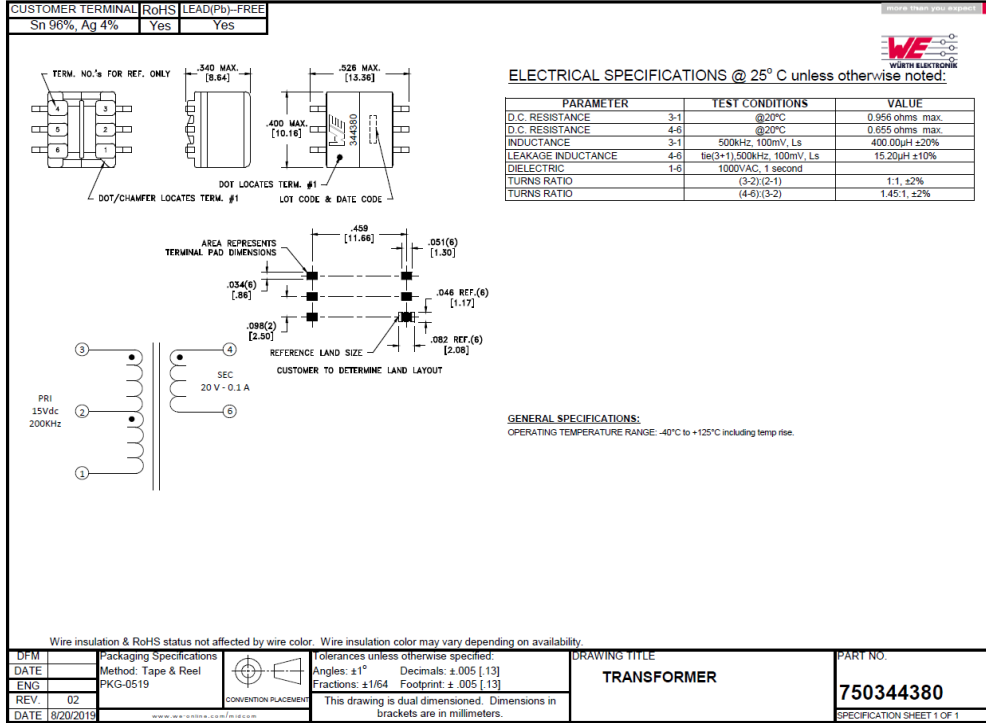

Figure 31.

Current Transformer: CT20, CT21, CT30, CT31, CT40, CT41

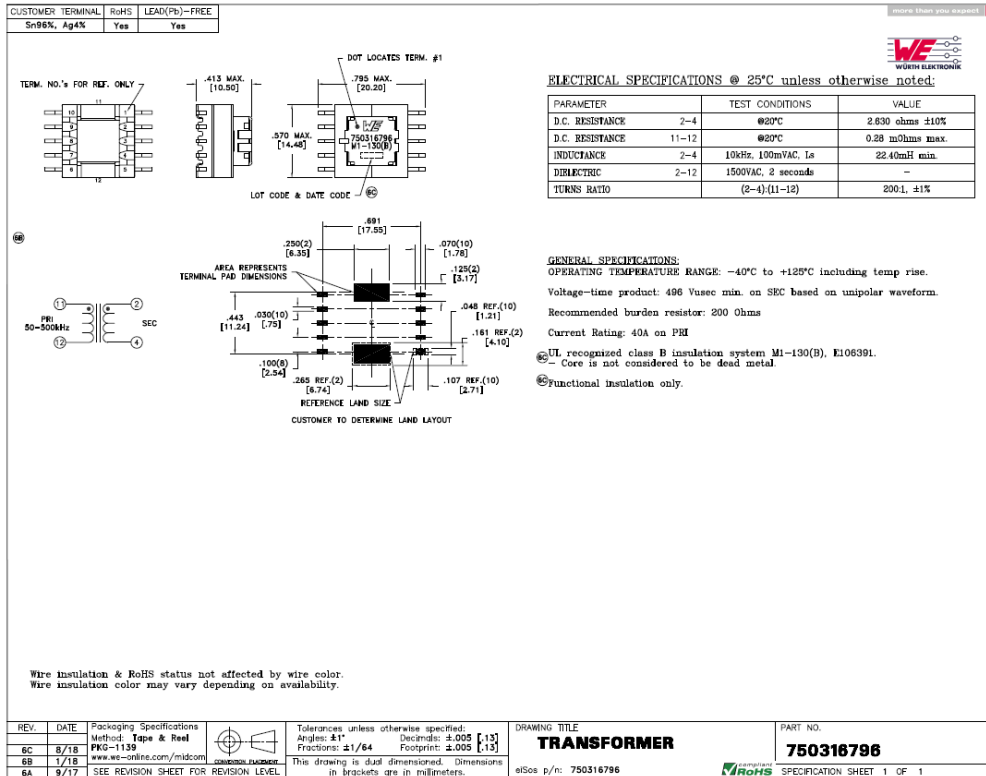

Figure 32.

PCB Layout

Top side view of main board. 228.6 x 177.8 mm.

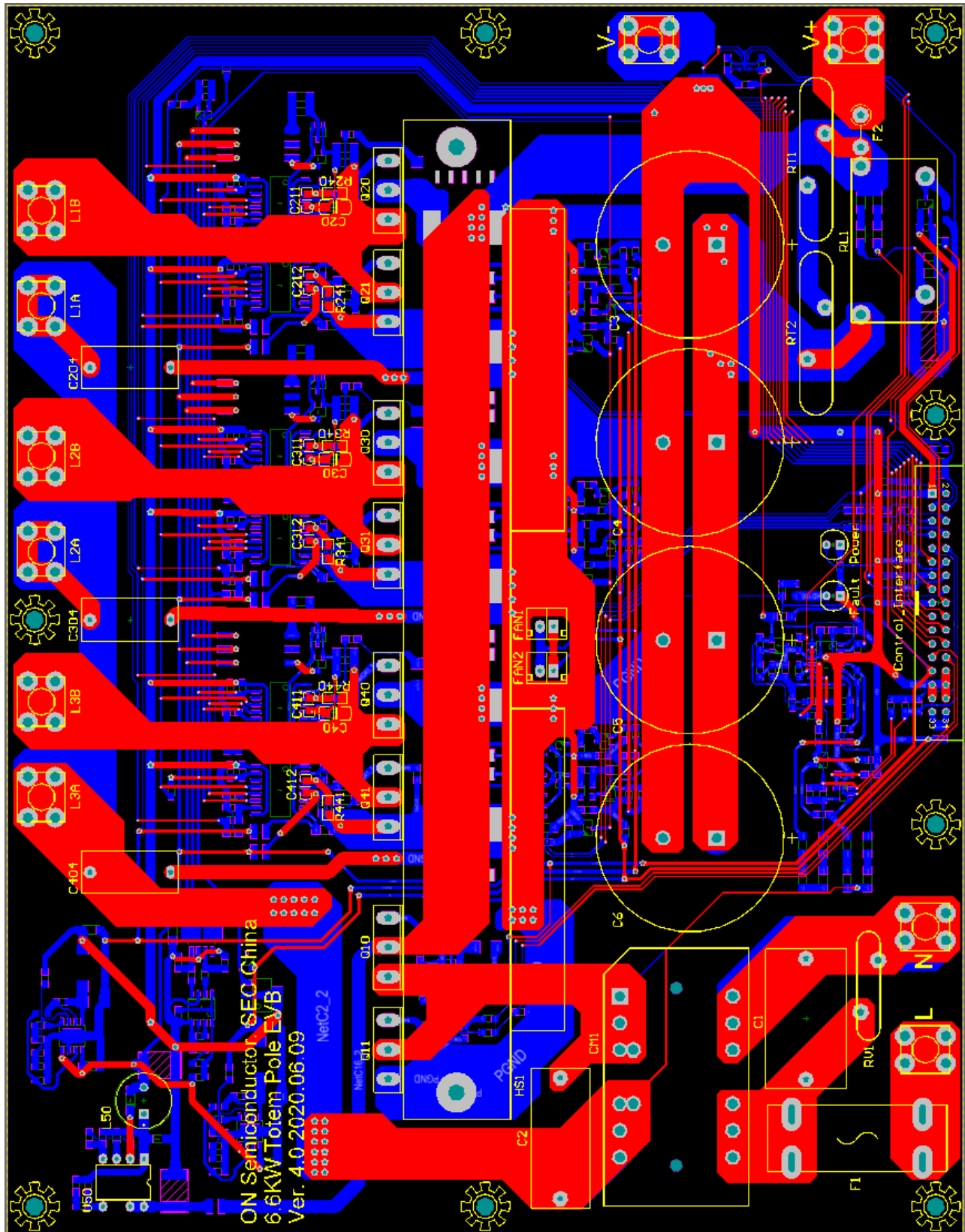

Figure 33. Top Side View of Main Board

EVBUM2784/D

Bottom side view of main board. 228.6 x 177.8 mm.

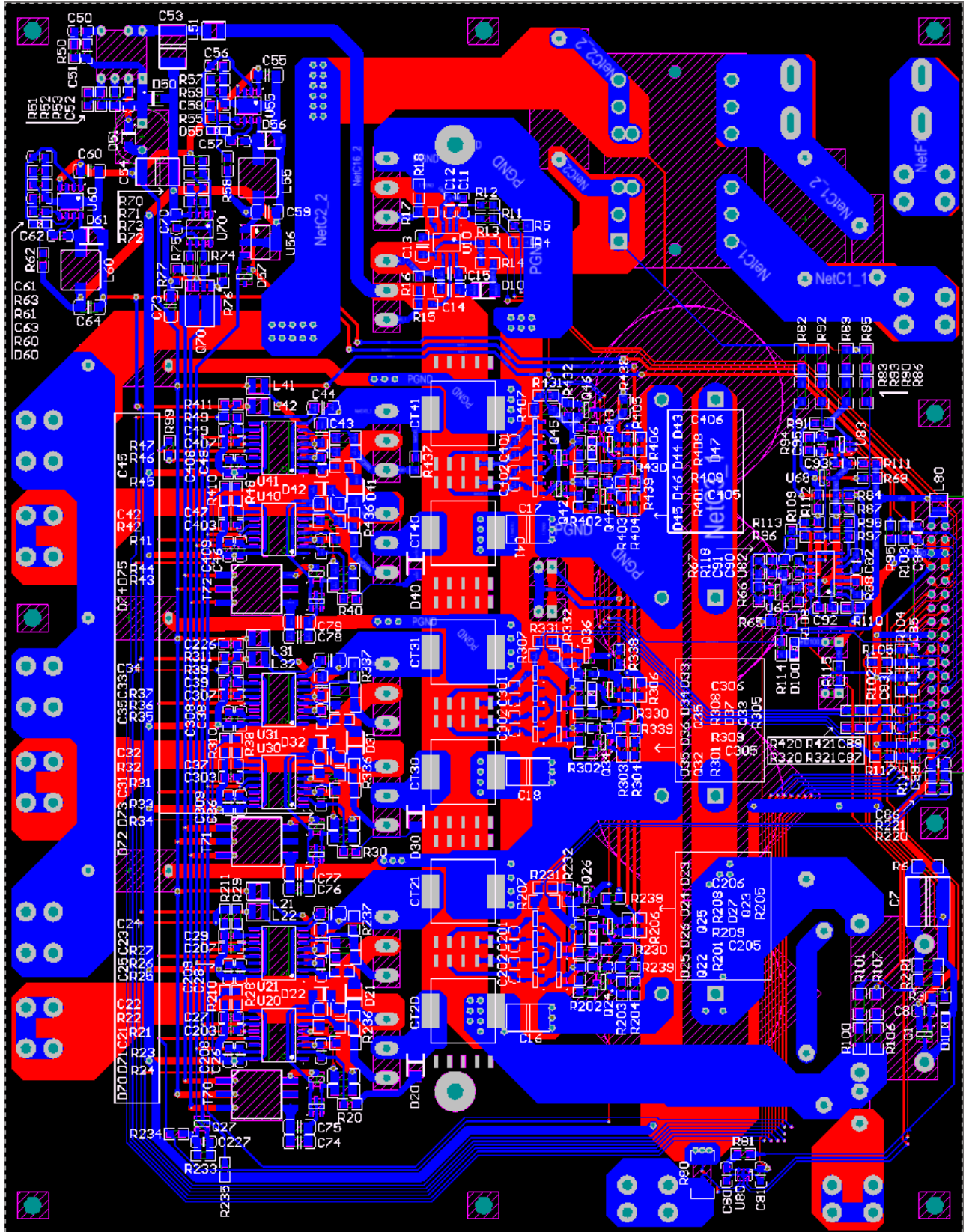

Figure 34. Bottom Side View of Main Board

EVBUM2784/D

Bill of Materials

Table 3. BILL OF MATERIALS

Description	Manufacturer Part Number	Manufacturer	Qty.	Designator
IC 600 V, 4.5 A, High & Low Side Gate Driver, Sop-8	FAN7191MX-F085	ON Semiconductor	1	U10
IC +4/-8 A Galvanic Isolated Gate Driver, SOIC-16W	NCV57000DWR2G	ON Semiconductor	6	U20, U21, U30, U31, U40, U41
IC 650 V Switcher for Buck Converters, PDIP-7	FSL336LRN	ON Semiconductor	1	U50
IC Buck Switcher, 1.2 A, 2 MHz, SO8EP	NCV890100PDR2G	ON Semiconductor	2	U55, U60
IC LDO 400 mA, 3.3 V, SOT-223	NCV4274CST33T3G	ON Semiconductor	1	U56
IC Shunt Regulator, SOT23-3L	SC431AVSNT1G	ON Semiconductor	2	U65, U68
IC Half-Bridge Controller, Sop-8	NCL30059BDR2G	ON Semiconductor	1	U70
IC Current Sense Amplifier, SC70-6	NCV210SQT2G	ON Semiconductor	1	U80
IC Quad, Single Supply Comparator, Sop-14	NCV2901DR2G	ON Semiconductor	1	U82
IC RRO OP Amplifier, SOT-23 5L	NCV2003SN2T1G	ON Semiconductor	1	U83
SiC MOSFET 60 mΩ 900 V, TO-247	NVHL060N090SC1	ON Semiconductor	6	Q20, Q21, Q30, Q31, Q40, Q41
MOSFET 25 mΩ 650V, TO-247	NVHL025N65S3	ON Semiconductor	2	Q10, Q11
MOSFET Dual N-Channel 60 V, 28 mΩ, SO8FL	NVMFD5C680NLT1G	ON Semiconductor	1	Q70
Transistor 40 V 0.6 A NPN, SOT23	SMMBT4401LT1G	ON Semiconductor	1	Q1
Transistor 40 V 0.6 A PNP, SOT23	SMMBT2907ALT1G	ON Semiconductor	10	Q22, Q23, Q25, Q27, Q32, Q33, Q35, Q42, Q43, Q45
Transistor 40 V 0.2 A NPN, SOT23	MMBT3904LT1G	ON Semiconductor	6	Q24, Q26, Q34, Q36, Q44, Q46
Diode 600 V 1 A 35 nS, SMA	ES1J	ON Semiconductor	7	D10, D20, D21, D30, D31, D40, D41
Diode 600 V 2 A 50 nS, SOD-123FL	NRVHP260SFT3G	ON Semiconductor	2	D50, D51
Schottky Diode 3 A 40 V, SMA	MBRA340T3G	ON Semiconductor	2	D56, D61
Schottky Diode Dual 0.2 A 30 V, SOT-23-3L	NSVBAT54SWT1G	ON Semiconductor	18	D23, D24, D25, D26, D33, D34, D35, D36, D43, D44, D45, D46, D70, D71, D72, D73, D74, D75
Switching Diode 0.2 A 100 V, SOD323	BAS16H	ON Semiconductor	7	D1, D27, D37, D47, D55, D60, D100
ZENER Diode 0.5 W 4.7 V, SOD123	SZMMSZ4V7T1G	ON Semiconductor	3	D22, D32, D42
LED D = 5 mm THT Green	151051VS04000	WURTH	1	Power
LED D = 5 mm THT Red	151051RS11000	WURTH	1	Fault
Chip resistor 0805 2.2 Ω -J		Any	6	R240, R241, R340, R341, R440, R441
Chip resistor 0805 10 Ω -J		Any	12	R13, R74, R75, R81, R110, R111, R238, R239, R338, R339, R438, R439
Chip resistor 0805 22 Ω -J		Any	2	R15, R17

EVBUM2784/D

Table 3. BILL OF MATERIALS (continued)

Description	Manufacturer Part Number	Manufacturer	Qty.	Designator
Chip resistor 0805 100 Ω -J		Any	12	R11, R12, R14, R28, R29, R38, R39, R48, R49, R59, R63, R70
Chip resistor 0805 470 Ω -J		Any	4	R58, R62, R114, R115
Chip resistor 0805 820 Ω -J		Any	2	R57, R61
Chip resistor 0805 1 k Ω -J		Any	16	R20, R25, R30, R35, R40, R45, R112, R203, R205, R209, R303, R305, R309, R403, R405, R409
Chip resistor 0805 2.2 k Ω -J		Any	27	R3, R68, R73, R88, R98, R99, R201, R202, R204, R206, R208, R210, R211, R301, R302, R304, R306, R308, R310, R311, R401, R402, R404, R406, R408, R410, R411
Chip resistor 0805 4.3 k Ω -J		Any	1	R52
Chip resistor 0805 4.42 k Ω -F		Any	2	R102, R104
Chip resistor 0805 4.7 k Ω J		Any	8	R231, R232, R234, R235, R331, R332, R431, R432
Chip resistor 0805 4.75 k Ω -F		Any	1	R103
Chip resistor 0805 6.2 k Ω -J		Any	1	R72
Chip resistor 0805 10 k Ω -J		Any	15	R50, R55, R60, R67, R109, R117, R220, R236, R237, R320, R336, R337, R420, R436, R437
Chip resistor 0805 12 k Ω -J		Any	3	R91, R94, R108
Chip resistor 0805 17.6 k Ω -F		Any	3	R84, R87, R95
Chip resistor 0805 18 k Ω -J		Any	3	R71, R76, R77
Chip resistor 0805 20 k Ω -J		Any	4	R66, R221, R321, R421
Chip resistor 0805 24 k Ω -J		Any	3	R51, R116, R118
Chip resistor 0805 30 k Ω -J		Any	2	R105, R218
Chip resistor 0805 39 k Ω -J		Any	1	R97
Chip resistor 0805 51 k Ω -J		Any	1	R96
Chip resistor 0805 100 k Ω -J		Any	3	R16, R18, R113
Chip resistor 1206 4.7 Ω -J		Any	6	R22, R27, R32, R37, R42, R47
Chip resistor 1206 10 Ω -J		Any	3	R207, R307, R407
Chip resistor 1206 15 Ω -J		Any	6	R21, R26, R31, R36, R41, R46
Chip resistor 1206 1 k Ω -J		Any	6	R1, R2, R6, R230, R330, R430
Chip resistor 1206 2.2 k Ω -J		Any	7	R23, R24, R33, R34, R43, R44, R65
Chip resistor 1206 1 M Ω -J		Any	12	R82, R83, R85, R86, R89, R90, R92, R93, R100, R101, R106, R107
Chip resistor 2512 2 m Ω -F	SMA25A2FR002T	SART	1	R80
Chip resistor 2512 2 m Ω -F	ERJMS4SF2M0*	Panasonic	1	R80
NTC 5 Ω D31	B57127P0509M301	TDK	2	RT1, RT2

EVBUM2784/D

Table 3. BILL OF MATERIALS (continued)

Description	Manufacturer Part Number	Manufacturer	Qty.	Designator
Disk Varistor 320V D20	820423211	WURTH	1	RV1
Disk Varistor 320V D20	B72220P3321K101V87	TDK	1	RV1
Disk Varistor 320V D20	V20E300AUTO	Littelfuse	1	RV1
MLCC 0805-450 V-100pFK-NP0	CGA4C4C0G2W101J	TDK	24	C11, C12, C21, C25, C27, C29, C31, C35, C37, C39, C41, C45, C47, C49, C82, C84, C85, C86, C87, C88, C89, C90, C91, C95
MLCC 0805-450 V-471J-NP0	CGA4C4C0G2W471J	TDK	2	C51, C227
MLCC 0805-100 V-102J-NP0	CGA4C2C0G2A102J	TDK	8	C83, C203, C207, C226, C303, C307, C403, C407
MLCC 0805-50V-222J-NP0	CGA4C2C0G1H222J	TDK	2	C58, C63
MLCC 0805-100 V-104K-X7R	CGA4J2X7R2A104K	TDK	21	C8, C26, C28, C36, C38, C46, C48, C56, C57, C61, C62, C80, C81, C92, C93, C205, C206, C305, C306, C405, C406
MLCC 0805-50 V-224K-X7R	CGA4J2X7R1H224K	TDK	1	C50
MLCC 0805-50 V-105K-X7R	CGA4J3X7R1H105K125 AB	TDK	8	C83, C203, C207, C226, C303, C307, C403, C407
MLCC 0805-25 V-225K-X7R	CGA4J3X7R1E225K	TDK	6	C208, C209, C308, C309, C408, C409
MLCC 1206-50 V-473J-NP0	CGA5H2C0G1H473J	TDK	6	C74, C75, C76, C77, C78, C79
MLCC 1206-25 V-106K-X7R	CGA5L1X7R1E106K	TDK	19	C13, C14, C15, C20, C22, C23, C24, C30, C32, C33, C34, C40, C42, C43, C44, C55, C59, C64, C73
MLCC 1206-50 V-475K-X7R	CGA5L3X7R1H475K	TDK	1	C60
MLCC 2220-630 V-105M-X7R	CAA572X7T2J105M	TDK	6	C16, C17, C18, C53, C129, C229
MLCC 2220-630 V-105M-X7R	KC355TD7LQ105MV01	MURATA	6	C16, C17, C18, C53, C129, C229
MLCC 2220-35 V-107M-X7R	CAA572X7R1V107M	TDK	1	C54
MLCC 2220-25 V-157M-X7R	CAA573X7R1E157M	TDK	1	C7
E-Cap 450 V-680 μ F-105 (35 x 57 mm)	861141486026	WURTH	4	C3, C4, C5, C6
E-Cap 450 V-680 μ F-105 (35 x 55 mm)	B43508A5687M062	TDK	4	C3, C4, C5, C6
X-Cap 275 VAC 0.47 μ F X2	890324025039CS	WURTH	3	C204, C304, C404
X-Cap 275 VAC 1 μ F X2	890324026027CS	WURTH	1	C2
X-Cap 275 VAC 1 μ F X2	ECQUAAF105T1	Panasonic	1	C2
X-Cap 275 VAC 2.2 μ F X2	890324026034CS	WURTH	1	C1
X-Cap 275 VAC 2.2 μ F X2	R46KN4220JHP0M	KEMET	1	C1
Common Choke 1.5 mH 38 A	7448063801	WURTH	1	CM1
Current Transformer EE13/7/4	750316796	WURTH	6	CT20, CT21, CT30, CT31, CT40, CT41
DCDC Transformer EP7	750344380	WURTH	3	T70, T71, T72

EVBUM2784/D

Table 3. BILL OF MATERIALS (continued)

Description	Manufacturer Part Number	Manufacturer	Qty.	Designator
SMD Inductor 3225-100 μ H-0.12 A	NLCV32T-101K-EFD	TDK	8	L21, L22, L31, L32, L41, L42, L51, L80
SMD Inductor 3225-100 μ H-0.26 A	LQH3NPH101MMEL	MURATA	8	L21, L22, L31, L32, L41, L42, L51, L80
SMD Inductor 3225-100 μ H-0.3 A	74403042101	WURTH	8	L21, L22, L31, L32, L41, L42, L51, L80
Radial Leaded Inductor 1014, 150 μ H, 2 A	7447480151	WURTH	1	L50
SMD Inductor 7 x 7 x 3.5 mm - 22 μ H - 1.6 A	784778220	WURTH	2	L55, L60
SMD Inductor 7 x 7 x 4.5 mm-22 μ H - 1.7 A	SPM7045VT-220M-D	TDK	2	L55, L60
SMD Inductor 7 x 7 x 4.5 mm-22 μ H - 2.9 A	ETQP4M220KFM	Panasonic	2	L55, L60
Connector 5 mm Screw type. 200 x 300 mil	74760050	WURTH	10	L, N, L1A, L1B, L2A, L2B, L3A, L3B, V+, V-
Connector WR-BHD Male Box Header 34 Pns	61203421621	WURTH	1	Control_Interface
FUSE 63A 500 V 10 x 32 mm	0606063.UXTHP	Littelfuse	1	F1
FUSE 30A 250 V 6 x 30 mm	0505030.MXEP	Littelfuse	1	F2
RELAY 33 A 250 VAC	ALFG2PF121	Panasonic	1	RL1

*The adjacent items in same shadow are optional in different manufacturer.

onsemi, **Onsemi**, and other names, marks, and brands are registered and/or common law trademarks of Semiconductor Components Industries, LLC dba "**onsemi**" or its affiliates and/or subsidiaries in the United States and/or other countries. **onsemi** owns the rights to a number of patents, trademarks, copyrights, trade secrets, and other intellectual property. A listing of **onsemi**'s product/patent coverage may be accessed at www.onsemi.com/site/pdf/Patent-Marking.pdf. **onsemi** is an Equal Opportunity/Affirmative Action Employer. This literature is subject to all applicable copyright laws and is not for resale in any manner.

The evaluation board/kit (research and development board/kit) (hereinafter the "board") is not a finished product and is not available for sale to consumers. The board is only intended for research, development, demonstration and evaluation purposes and will only be used in laboratory/development areas by persons with an engineering/technical training and familiar with the risks associated with handling electrical/mechanical components, systems and subsystems. This person assumes full responsibility/liability for proper and safe handling. Any other use, resale or redistribution for any other purpose is strictly prohibited.

THE BOARD IS PROVIDED BY ONSEMI TO YOU "AS IS" AND WITHOUT ANY REPRESENTATIONS OR WARRANTIES WHATSOEVER. WITHOUT LIMITING THE FOREGOING, ONSEMI (AND ITS LICENSORS/SUPPLIERS) HEREBY DISCLAIMS ANY AND ALL REPRESENTATIONS AND WARRANTIES IN RELATION TO THE BOARD, ANY MODIFICATIONS, OR THIS AGREEMENT, WHETHER EXPRESS, IMPLIED, STATUTORY OR OTHERWISE, INCLUDING WITHOUT LIMITATION ANY AND ALL REPRESENTATIONS AND WARRANTIES OF MERCHANTABILITY, FITNESS FOR A PARTICULAR PURPOSE, TITLE, NON-INFRINGEMENT, AND THOSE ARISING FROM A COURSE OF DEALING, TRADE USAGE, TRADE CUSTOM OR TRADE PRACTICE.

onsemi reserves the right to make changes without further notice to any board.

You are responsible for determining whether the board will be suitable for your intended use or application or will achieve your intended results. Prior to using or distributing any systems that have been evaluated, designed or tested using the board, you agree to test and validate your design to confirm the functionality for your application. Any technical, applications or design information or advice, quality characterization, reliability data or other services provided by **onsemi** shall not constitute any representation or warranty by **onsemi**, and no additional obligations or liabilities shall arise from **onsemi** having provided such information or services.

onsemi products including the boards are not designed, intended, or authorized for use in life support systems, or any FDA Class 3 medical devices or medical devices with a similar or equivalent classification in a foreign jurisdiction, or any devices intended for implantation in the human body. You agree to indemnify, defend and hold harmless **onsemi**, its directors, officers, employees, representatives, agents, subsidiaries, affiliates, distributors, and assigns, against any and all liabilities, losses, costs, damages, judgments, and expenses, arising out of any claim, demand, investigation, lawsuit, regulatory action or cause of action arising out of or associated with any unauthorized use, even if such claim alleges that **onsemi** was negligent regarding the design or manufacture of any products and/or the board.

This evaluation board/kit does not fall within the scope of the European Union directives regarding electromagnetic compatibility, restricted substances (RoHS), recycling (WEEE), FCC, CE or UL, and may not meet the technical requirements of these or other related directives.

FCC WARNING – This evaluation board/kit is intended for use for engineering development, demonstration, or evaluation purposes only and is not considered by **onsemi** to be a finished end product fit for general consumer use. It may generate, use, or radiate radio frequency energy and has not been tested for compliance with the limits of computing devices pursuant to part 15 of FCC rules, which are designed to provide reasonable protection against radio frequency interference. Operation of this equipment may cause interference with radio communications, in which case the user shall be responsible, at its expense, to take whatever measures may be required to correct this interference.

onsemi does not convey any license under its patent rights nor the rights of others.

LIMITATIONS OF LIABILITY: **onsemi** shall not be liable for any special, consequential, incidental, indirect or punitive damages, including, but not limited to the costs of requalification, delay, loss of profits or goodwill, arising out of or in connection with the board, even if **onsemi** is advised of the possibility of such damages. In no event shall **onsemi**'s aggregate liability from any obligation arising out of or in connection with the board, under any theory of liability, exceed the purchase price paid for the board, if any.

The board is provided to you subject to the license and other terms per **onsemi**'s standard terms and conditions of sale. For more information and documentation, please visit www.onsemi.com.

ADDITIONAL INFORMATION

TECHNICAL PUBLICATIONS:

Technical Library: www.onsemi.com/design/resources/technical-documentation
onsemi Website: www.onsemi.com

ONLINE SUPPORT: www.onsemi.com/support

For additional information, please contact your local Sales Representative at www.onsemi.com/support/sales