

# 200DPI Contact Image Sensor Module with Binary Output

## NOM02B4-DR11G

### Description

The NOM02B4-DR11G contact image sensor (CIS) module integrates a red LED light source, lens and image sensor in a compact housing. The module is designed for document scanning, mark reading, gaming and office automation equipment applications and is suitable for scanning documents up to 256 mm wide with a scanning rate of 410  $\mu$ sec/line. The analog output signal is processed by a digitizing comparator referenced to an externally supplied voltage level to produce a serial digital output. The NOM02B4-DR11G module employs proprietary CMOS image sensing technology from onsemi to achieve high-speed performance and high sensitivity.

### Features

- Light Source, Lens and Sensor are Integrated Into a Single Module
- 256 mm Scanning Width at 8 dots per mm Resolution
- 410  $\mu$ sec/Line Scanning Speed @ 5.0 MHz Pixel Rate
- Two-Level Tracking Digital Output
- Differential LVDS Input and Output Signals
- Supports B4 Paper Size at up to 52 Pages per Minute
- Red LED Light Source
- Wide Dynamic Range, Low Power
- Compact 272.0 mm x 24.3 mm x 21.5 mm Module Housing
- Light Weight 2.4 oz Packaging
- These Devices are Pb-Free, Halogen Free/BFR Free and are RoHS Compliant

### Applications

- Mark Readers Including Balloting, Test Scoring and Gaming Machines
- Document Scanning
- Office Automation Equipment

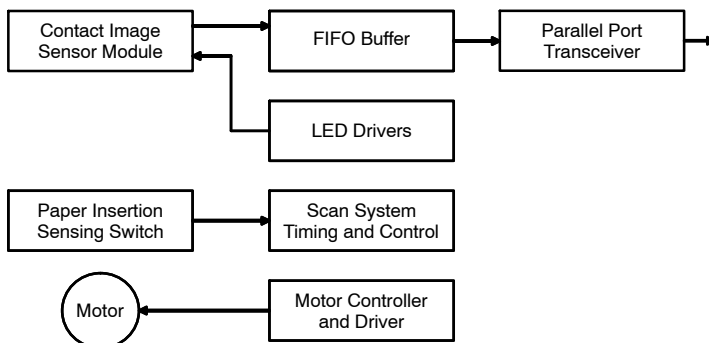


Figure 1. Typical Scanner Application

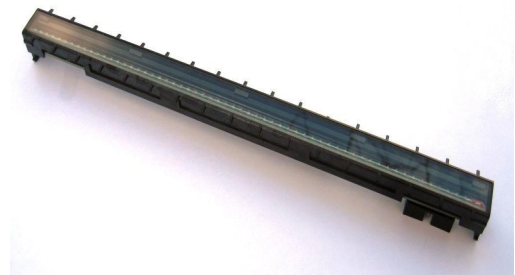


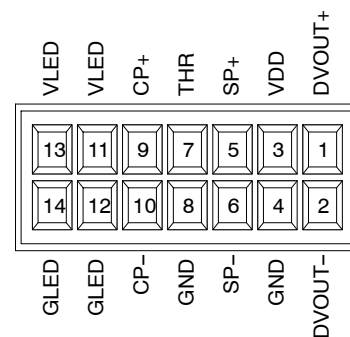
IMAGE SENSOR MODULE B4  
CASE MODAJ

### MARKING DIAGRAM



- YY = Year
- MM = Month
- SSSSSS = Serial Number
- G = Pb-Free Package

### CONNECTOR PIN ASSIGNMENT



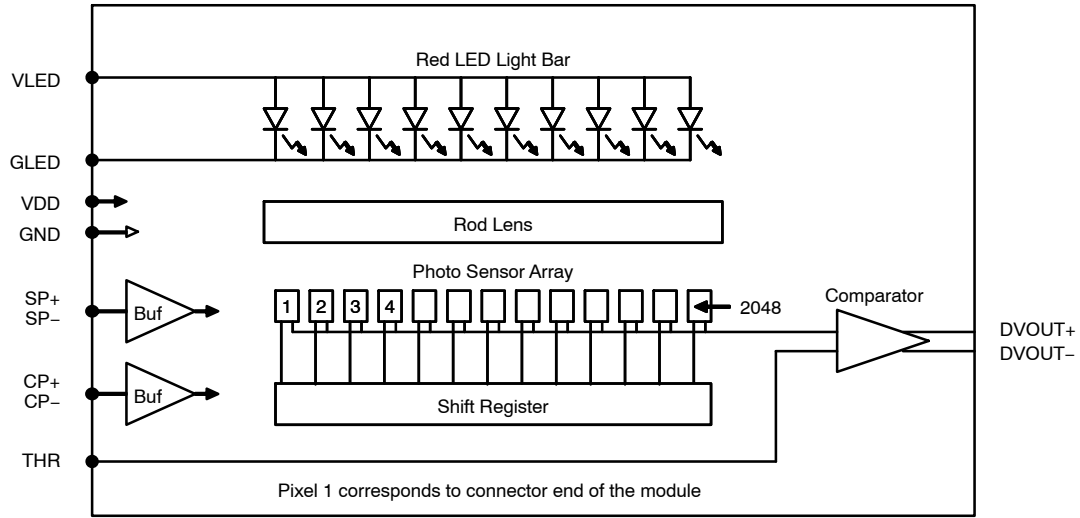
### ORDERING INFORMATION

See detailed ordering and shipping information in the package dimensions section on page 2 of this data sheet.

# NOM02B4-DR11G

**Table 1. ORDERING INFORMATION**

Part Number	Package	Shipping Configuration
NOM02B4-DR11G	(Pb-Free)	100 per packing carton



**Figure 2. Simplified Block Diagram**

**Table 2. PIN FUNCTION DESCRIPTION**

Pin	Pin Name	Description
1	DVOUT+	Digital Video Output (+)
2	DVOUT-	Digital Video Output (-)
3	VDD	+5 V power supply
4	GND	Ground
5	SP+	Shift register start pulse (+)
6	SP-	Shift register start pulse (-)
7	THR	Reference voltage input
8	GND	Ground
9	CP+	Sampling clock pulse (+)
10	CP-	Sampling clock pulse (-)
11	VLED	Power supply for the LED light source
12	GLED	Ground for the LED light source
13	VLED	Power supply for the LED light source
14	GLED	Ground for the LED light source

# NOM02B4-DR11G

**Table 3. ABSOLUTE MAXIMUM RATINGS**

Parameter	Symbol	Value	Unit
Power supply voltage	$V_{DD}$	7	V
	$V_{LED}$	6	V
Power supply current	$I_{LED}$	980	mA
Input voltage range for SP $\pm$ , CP $\pm$	$V_{in}$	-0.5 to $V_{DD} + 0.5$	V
Input voltage range for THR	$V_{in\_thr}$	0 to $V_{DD}$	V
Storage Temperature	$T_{STG}$	-20 to 75	°C
Storage Humidity, Non-Condensing	$H_{STG}$	10 to 90	%
ESD Capability, Contact Discharge (Note 1)	$ESD_{HBM}$	$\pm 2$	kV

Stresses exceeding those listed in the Maximum Ratings table may damage the device. If any of these limits are exceeded, device functionality should not be assumed, damage may occur and reliability may be affected.

1. This module assembly has been ESD tested to IEC61000-4-2 (HBM) Contact Discharge

**Table 4. RECOMMENDED OPERATING RANGES** (Unless otherwise specified, these specifications apply  $T_A = 25^\circ\text{C}$ ) (Note 2)

Parameter	Symbol	Min	Typ	Max	Unit
Power supply voltage (Note 3)	$V_{DD}$	4.5	5	5.5	V
	$V_{LED}$	4.5	5	5.5	V
Power supply current	$I_{DD}$	86	96	106	mA
	$I_{LED}$	630	650	670	mA
Low level input voltage for SP $\pm$ , CP $\pm$	$V_{IL}$	0	0	0.8	V
High level input voltage for SP $\pm$ , CP $\pm$	$V_{IH}$	4.5	5.0	$V_{DD} + 0.3$	V
Threshold voltage level	$V_{THR}$	1.2	1.75	2.3	V
Low level output voltage (digital output level for dark)	$V_{OL}$		0.8		V
High level output voltage (digital output level for white)	$V_{OH}$		4.0		V
Line scanning rate (Note 4)	$T_{int}$	372	410	1024	$\mu\text{s}$
Clock frequency (Note 5)	f	2.0	5.0	5.5	MHz
Clock period	$t_o$	182	200	500	ns
Clock pulse width (Note 6)	$t_w$	46	50	125	ns
Clock pulse high duty cycle	$DC_{CP}$	20	25	75	%
Start pulse width (Note 6)	$t_{wSP}$	150	180	480	ns
Start pulse setup time	$t_{su}$	20			ns
Start pulse hold time	$t_h$	20			ns
Prohibit crossing time (Note 7)	$t_{prh}$	20			ns
Clock to Video output propagation delay rising	$t_{pcor}$	115			ns
Clock to Video output propagation delay falling	$t_{pcof}$	20			ns
Operating Temperature	$T_{op}$	0		50	°C
Operating Humidity, Non-Condensing	$H_{op}$	10		60	%

2. Refer to Figure 3 for more information on AC characteristics

3.  $V_{LED}$  directly affects illumination intensity, which directly affects  $DV_{OUT}$ .

4.  $T_{int}$  is the line scanning rate or integration time.  $T_{int}$  is determined by the interval between two start pulses. The clock is proportional to  $T_{int}$ .

5. Main clock frequency (f) corresponds to the video sampling frequency.

6. Min, Typ, Max specifications reflect operation at the corresponding Min, Typ, Max clock frequency.

7. Prohibit crossing time is to insure that two start pulses are not supplied in the same scan line time. SP may only be active high during one falling edge of CP for any given scan.

# NOM02B4-DR11G

**Table 5. PHYSICAL SPECIFICATIONS**

Parameter	Symbol	Typ	Unit
Scan width	PD <sub>w</sub>	256	mm
Number of Photo Detector Arrays	PDA <sub>n</sub>	32	arrays
Number of Photo Detectors	PD <sub>n</sub>	2048	elements

**Table 6. PHYSICAL CHARACTERISTICS**

Parameter	Symbol	Min	Typ	Max	Unit
Pixel pitch	PD <sub>sp</sub>		125		μm
Inter-array spacing	PDA <sub>sp</sub>	150	180	210	μm
Inter-array vertical alignment	PDA <sub>vxp</sub>	-40	0	40	μm
Red LED peak wavelength	λ <sub>p</sub>	634		644	nm

**Table 7. ELECTRO-OPTICAL CHARACTERISTICS TEST CONDITIONS**

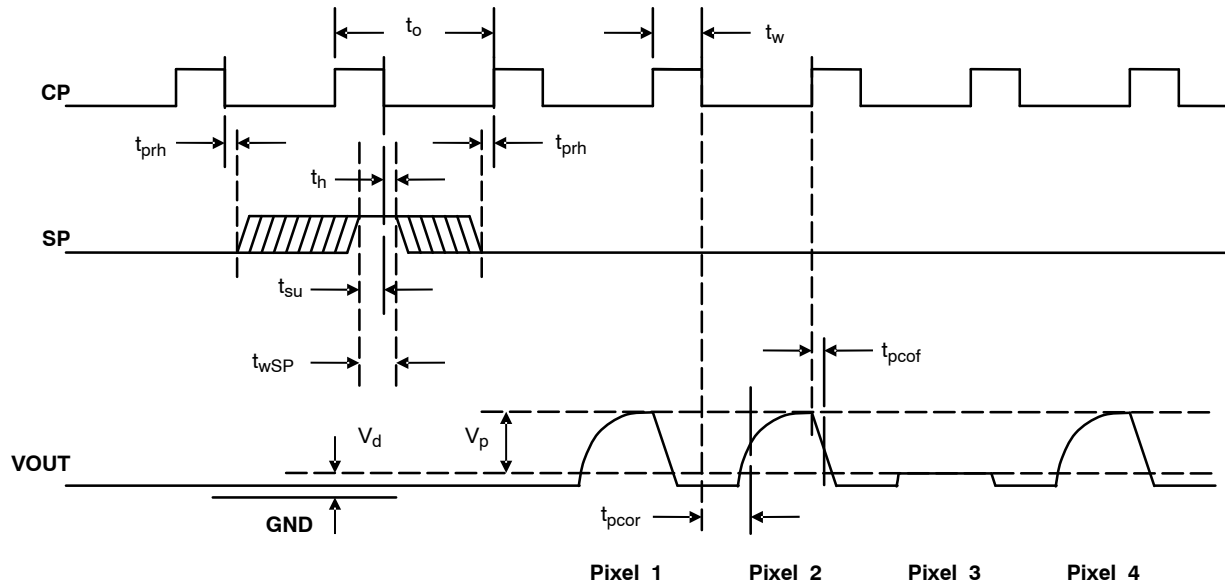
Parameter	Symbol	Value	Unit
Power supply voltage	V <sub>DD</sub>	5.0	V
	V <sub>SS</sub>	-5.0	V
	V <sub>LED</sub>	5.0	V
Clock frequency	f	5.0	MHz
Clock pulse high duty cycle	DC <sub>CP</sub>	25	%
Line scanning rate	T <sub>int</sub>	410	μs
Operating Temperature	T <sub>op</sub>	25	°C

# NOM02B4-DR11G

**Table 8. ELECTRO-OPTICAL CHARACTERISTICS** (Unless otherwise specified, these specifications were achieved with the test conditions defined in Table 7)

Parameter	Symbol	Min	Typ	Max	Unit
Bright analog output voltage (Note 8)	$V_{pavg}$	0.8	1.0	1.2	V
Bright output non-uniformity (Note 9)	$U_p$	-30		30	%
Bright output non-uniformity total (Note 10)	$U_{ptotal}$			60	%
Adjacent pixel non-uniformity (Note 11)	$U_{p adj}$			25	%
Dark output voltage (Note 12)	$V_d$			1500	mV
Dark non-uniformity (Note 13)	$U_d$			60	mV
Modulation transfer function at 50 line pairs per in (lp/in) (Note 14)	$MTF_{50}$	40			%
Modulation transfer function at 100 line pairs per in (lp/in) (Notes 14, 15)	$MTF_{100}$	20			%

8.  $V_{pavg} = \sum V_{p(n)}/2048$ , where  
 $V_p$  is the pixel amplitude value for a bright signal defined as a white document with LEDs turned on,  
 $n$  is the sequential pixel number in one scan line.
9.  $U_p = [(V_{pmax} - V_{pavg})/V_{pavg}] \times 100\%$ , or  $[V_{pavg} - V_{pmin})/V_{pavg}] \times 100\%$ , whichever is greater, where  
 $V_{pmax}$  is the maximum pixel voltage of any pixel at full bright  
 $V_{pmin}$  is the minimum pixel voltage of any pixel at full bright
10.  $U_{ptotal} = [(V_{pmax} - V_{pmin})/V_{pavg}] \times 100\%$ ,
11.  $U_{p adj} = \text{MAX} [ | (V_{p(n)} - V_{p(n+1)}) / V_{p(n)} | \times 100\%$ , where  
 $U_{p adj}$  is the nonuniformity in percent between adjacent pixels for a bright background
12.  $V_d$  is the pixel amplitude value for a dark signal defined as a black document with LEDs turned off
13.  $U_d = V_{dmax} - V_{dmin}$ , where  
 $V_{dmax}$  is the maximum pixel voltage of any dark pixel with the LEDs turned off  
 $V_{dmin}$  is the minimum pixel voltage of any dark pixel with the LEDs turned off
14.  $MTF = [(V_{max} - V_{min})/(V_{max} + V_{min})] \times 100\%$ , where  
 $V_{max}$  is the maximum output voltage at the specified line pairs per inch (lp/in)  
 $V_{min}$  is the minimum output voltage at the specified lp/in
15. For information only.



**Figure 3. Timing Diagram**

DESCRIPTION OF OPERATION

Functional Description

The NOM02B4-DR11G module consists of 32 contact image sensors, each with 64 pixel elements, that are cascaded to provide 2048 photo-detectors with their associated multiplex switches and double-buffered digital shift register that controls its sequential readout. The analog pixel signal is proportional to the exposure on the corresponding picture elements on the document. A comparator digitizes the analog pixels into a serial binary bit stream as each pixel is compared to the external reference voltage THR as shown in Figure 2. In operation, the sensor module produces a binary one for each pixel with a voltage above THR and a binary zero for each pixel with a voltage below THR. The DVOUT signal outputs 2048 pixels for each scan line. The first bit shifted out from DVOUT during each scan represents the first pixel on the connector end of the module.

A pictorial of the NOM02B4-DR11G cross section view is shown in Figure 4. Mounted in the module is a one-to-one graded-index micro lens array that focuses the scanned document image onto the sensing plane. Illumination is accomplished by means of an integrated LED light source. All components are housed in a small plastic housing, which has a glass cover. The top surface of the glass acts as the focal point for the object being scanned and protects the imaging array, micro lens assembly and LED light source from dust.

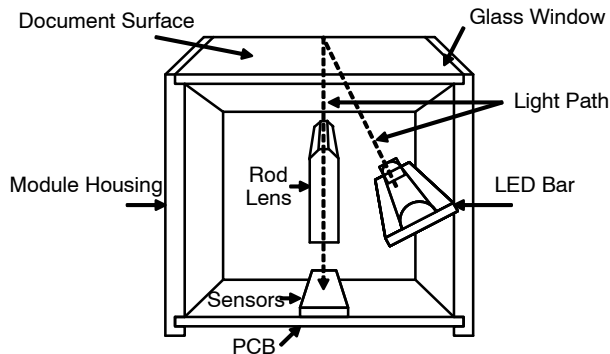


Figure 4. Module Cross Section View

Digital Video Output

The NOM02B4-DR11G module only presents a digital output, however module performance is best understood by analyzing the analog nature of the internal circuitry. Characterization of the analog signal is presented in Table 4.

Connector Pin Out Description

Connections to the module are via a 9.14x25.40mm 14-pin connector (AMP part number 103308-2) located at one end of the module as shown in the package drawing. The location of pin number 1 is indicated on the package drawing.

Scanner Applications

A typical use of the NOM02B4-DR11G module in scanner applications is shown in Figure 6. The document to

be digitized is fed into the scanner where a sensor detects its presence. The scanner then operates the motor to move the paper under the contact image sensor module. The module illuminates the paper with internal LEDs and the image sensor pixel array detects the amount of reflected light and simultaneously measures a full line of pixels which are sampled and transferred to a FIFO for storage and conversion to a parallel output format. Once the pixel line is processed, the motor advances the paper and the next scan line is captured.

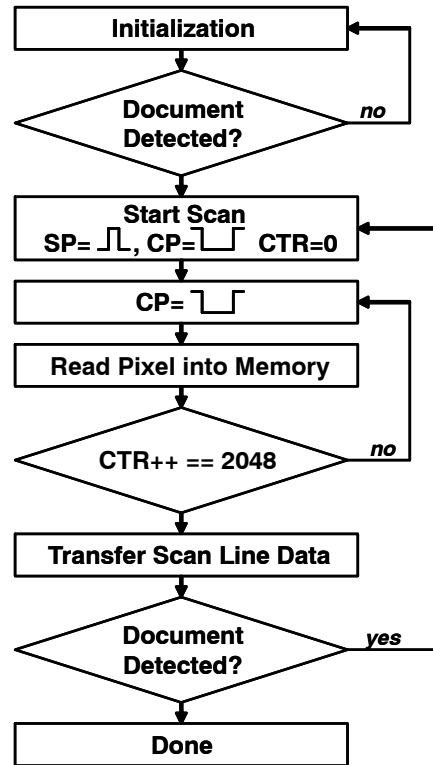


Figure 5. Typical Scanner Algorithm

Figure 5 outlines the basic steps in the scanner control sequence. First the circuits are initialized and the scanner waits for a document to be detected, usually by a paper sensing switch. Then a start pulse and clock pulse are supplied to capture a line image. At the next clock pulse the first pixel value appears on the output. The pixel can be stored in a local line buffer memory. Subsequent clocks cause the remaining pixels to be shifted out and stored in the line buffer. Once the complete line has been shifted out it can be transferred to the host application and the system advances the paper and the line scan process repeats until the paper sensing switch indicates the document has passed completely through the scanner.

# NOM02B4-DR11G

## Device Marking and Barcode Description

Each module is marked with a tag that contains the part number, a number combining the manufacturing date code and serial number and a barcode. The barcode presents the date code and serial number in Interleave 2 of 5 barcode format as follows

YYMMSSSSSS

where

YY is the year,

MM is the month, and

SSSSSS is the serial number.

## Glass Lens Care

Precautions should be taken to avoid scratching or touching the glass lens. The glass lens may be cleaned with alcohol.

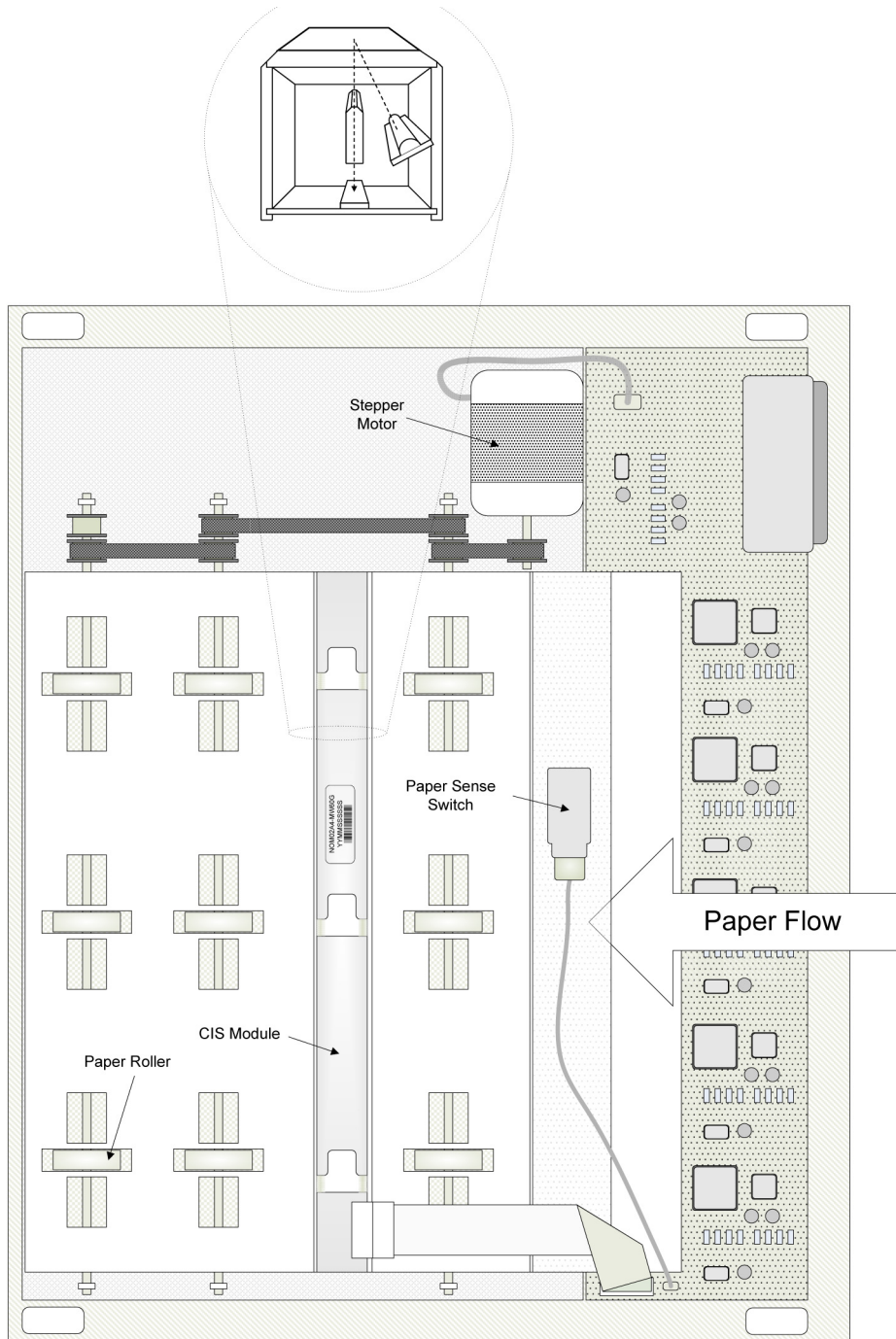
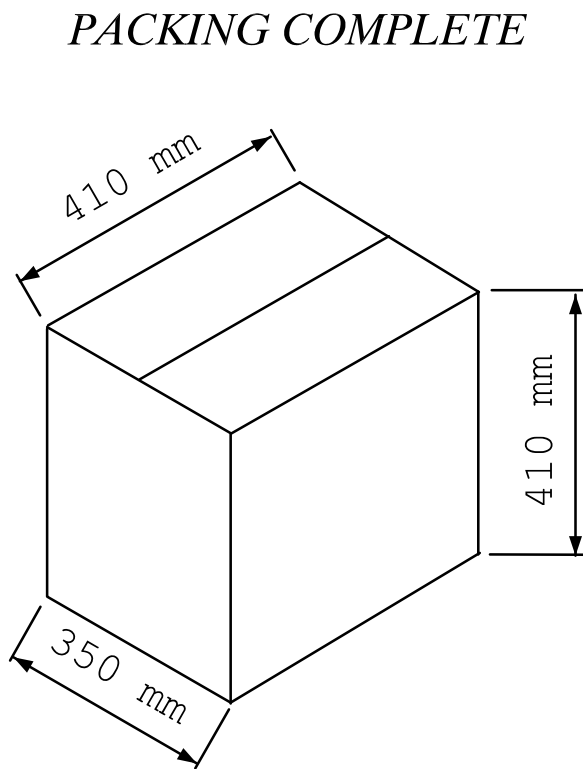
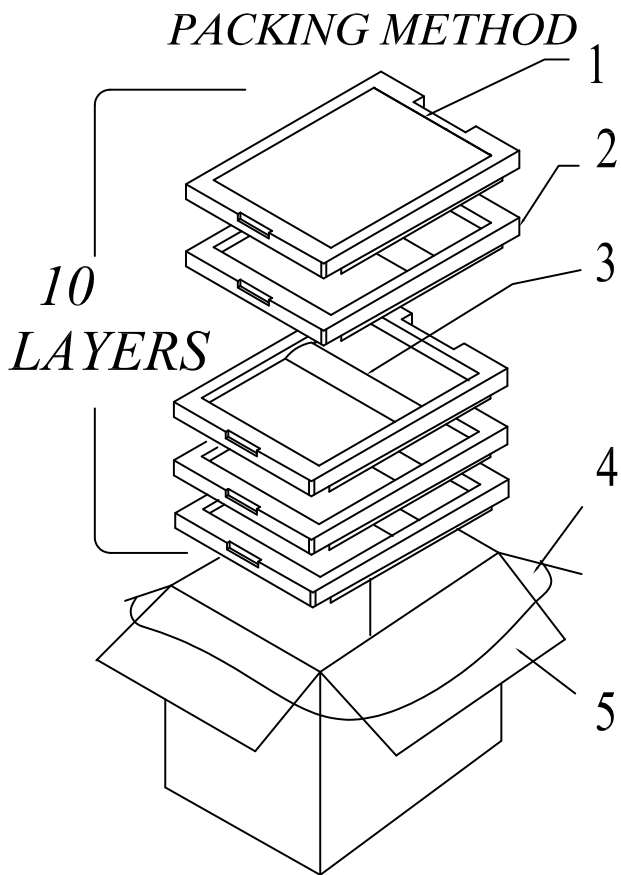


Figure 6. Typical Scanner Assembly

PACKING DIMENSIONS



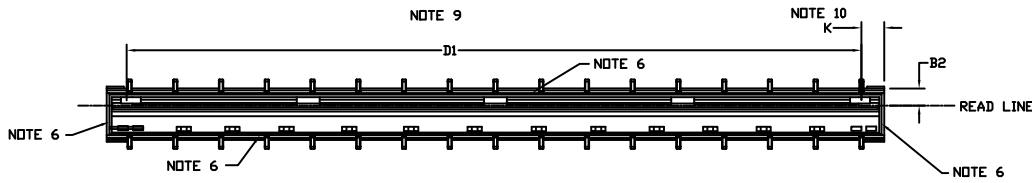
NO.	NAME	MATERIAL
1	Shockproof Pad	EPE
2	Packing Tray	POLYFOAM
3	Conduct Electricity Sheet	PE + CONDUCTIVE SHEET
4	Waterproof Bag	PE
5	Packing Box-Carton	KRAFT PAPER



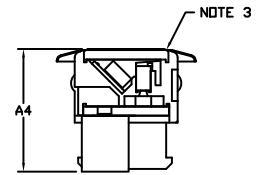


**IMAGE SENSOR MODULE**  
**CASE MODAJ**  
**ISSUE O**

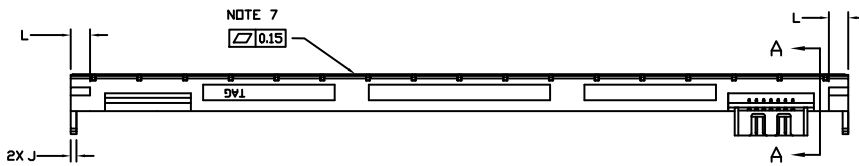
DATE 18 MAY 2010



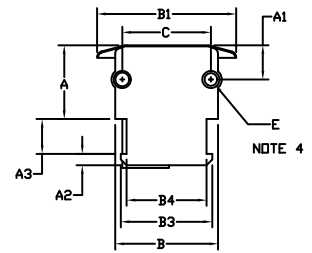
TOP VIEW



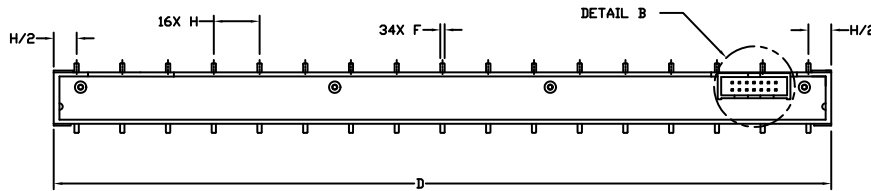
SECT. A-A  
2X SCALE



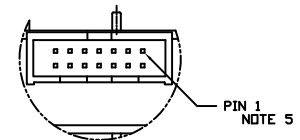
SIDE VIEW



END VIEW  
2X SCALE



BOTTOM VIEW



DETAIL B  
2X SCALE

DIM	MILLIMETERS	
	MIN	MAX
A	12.60	13.20
A1	5.63	5.93
A2	1.90	2.10
A3	5.98	6.18
A4	21.45	REF
B	17.70	18.30
B1	24.32	REF
B2	5.50	6.50
B3	15.85	16.15
B4	13.85	14.15
C	15.35	15.65
D	271.50	272.50
D1	256.00	REF
E	2.05	2.35
F	1.51	REF
H	16.00	REF
J	2.00	REF
K	7.00	9.00
L	6.80	REF

- NOTES:
1. DIMENSIONING AND TOLERANCING PER ASME Y14.5M, 1994.
  2. CONTROLLING DIMENSION: MILLIMETERS.
  3. LEADING EDGE OF THE APPROACH ANGLE ON THE GLASS IS LOWER THAN THE TOP OF THE HOUSING.
  4. BORE DEPTH IS 6.0.
  5. CONNECTOR, AMP MODEL NUMBER 103308-2, 2X7 PIN, PITCH 2.54.
  6. GLASS IS GLUED ON ALL 4 SIDES.
  7. GLASS THICKNESS IS 1.85.
  8. USE M2.3 SELF TAPPING SCREWS FOR MOUNTING. TORQUE SCREWS BETWEEN 1.80 KGF-CM AND 2.00 KGF-CM.
  9. DIMENSION D1 DENOTES THE SCAN LENGTH.
  10. DIMENSION K DENOTES THE POSITION OF THE FIRST PIXEL.

<b>DOCUMENT NUMBER:</b>	<b>98AON51324E</b>	Electronic versions are uncontrolled except when accessed directly from the Document Repository. Printed versions are uncontrolled except when stamped "CONTROLLED COPY" in red.
<b>STATUS:</b>	<b>ON SEMICONDUCTOR STANDARD</b>	
<b>NEW STANDARD:</b>		
<b>DESCRIPTION:</b>	<b>IMAGE SENSOR MODULE MODAJ</b>	<b>PAGE 1 OF 2</b>



**onsemi**, **Onsemi**, and other names, marks, and brands are registered and/or common law trademarks of Semiconductor Components Industries, LLC dba "**onsemi**" or its affiliates and/or subsidiaries in the United States and/or other countries. **onsemi** owns the rights to a number of patents, trademarks, copyrights, trade secrets, and other intellectual property. A listing of **onsemi**'s product/patent coverage may be accessed at [www.onsemi.com/site/pdf/Patent-Marking.pdf](http://www.onsemi.com/site/pdf/Patent-Marking.pdf). **onsemi** reserves the right to make changes at any time to any products or information herein, without notice. The information herein is provided "as-is" and **onsemi** makes no warranty, representation or guarantee regarding the accuracy of the information, product features, availability, functionality, or suitability of its products for any particular purpose, nor does **onsemi** assume any liability arising out of the application or use of any product or circuit, and specifically disclaims any and all liability, including without limitation special, consequential or incidental damages. Buyer is responsible for its products and applications using **onsemi** products, including compliance with all laws, regulations and safety requirements or standards, regardless of any support or applications information provided by **onsemi**. "Typical" parameters which may be provided in **onsemi** data sheets and/or specifications can and do vary in different applications and actual performance may vary over time. All operating parameters, including "Typicals" must be validated for each customer application by customer's technical experts. **onsemi** does not convey any license under any of its intellectual property rights nor the rights of others. **onsemi** products are not designed, intended, or authorized for use as a critical component in life support systems or any FDA Class 3 medical devices or medical devices with a same or similar classification in a foreign jurisdiction or any devices intended for implantation in the human body. Should Buyer purchase or use **onsemi** products for any such unintended or unauthorized application, Buyer shall indemnify and hold **onsemi** and its officers, employees, subsidiaries, affiliates, and distributors harmless against all claims, costs, damages, and expenses, and reasonable attorney fees arising out of, directly or indirectly, any claim of personal injury or death associated with such unintended or unauthorized use, even if such claim alleges that **onsemi** was negligent regarding the design or manufacture of the part. **onsemi** is an Equal Opportunity/Affirmative Action Employer. This literature is subject to all applicable copyright laws and is not for resale in any manner.

## ADDITIONAL INFORMATION

### TECHNICAL PUBLICATIONS:

Technical Library: [www.onsemi.com/design/resources/technical-documentation](http://www.onsemi.com/design/resources/technical-documentation)  
onsemi Website: [www.onsemi.com](http://www.onsemi.com)

### ONLINE SUPPORT: [www.onsemi.com/support](http://www.onsemi.com/support)

For additional information, please contact your local Sales Representative at [www.onsemi.com/support/sales](http://www.onsemi.com/support/sales)