

# MC1496, MC1496B

## Balanced Modulators/ Demodulators

These devices were designed for use where the output voltage is a product of an input voltage (signal) and a switching function (carrier). Typical applications include suppressed carrier and amplitude modulation, synchronous detection, FM detection, phase detection, and chopper applications. See ON Semiconductor Application Note AN531 for additional design information.

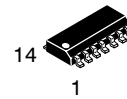
### Features

- Excellent Carrier Suppression  $-65$  dB typ @  $0.5$  MHz  
 $-50$  dB typ @  $10$  MHz
- Adjustable Gain and Signal Handling
- Balanced Inputs and Outputs
- High Common Mode Rejection  $-85$  dB Typical
- This Device Contains 8 Active Transistors
- Pb-Free Package is Available\*

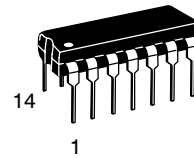


**ON Semiconductor®**

<http://onsemi.com>

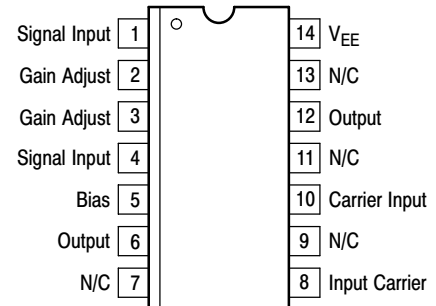


**SOIC-14  
D SUFFIX  
CASE 751A**



**PDIP-14  
P SUFFIX  
CASE 646**

### PIN CONNECTIONS



### ORDERING INFORMATION

See detailed ordering and shipping information in the package dimensions section on page 12 of this data sheet.

### DEVICE MARKING INFORMATION

See general marking information in the device marking section on page 12 of this data sheet.

# MC1496, MC1496B

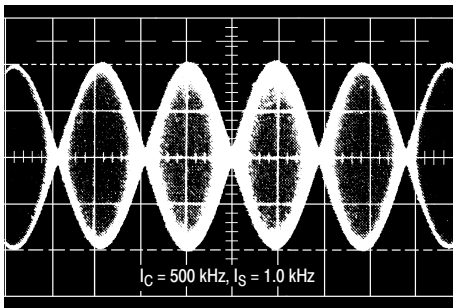


Figure 1. Suppressed Carrier Output Waveform

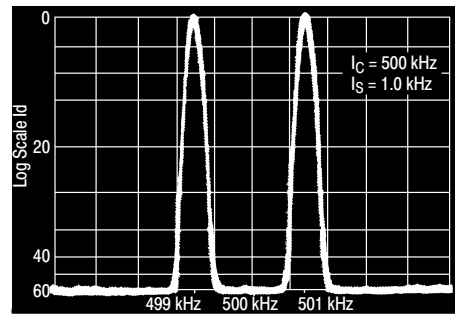


Figure 2. Suppressed Carrier Spectrum

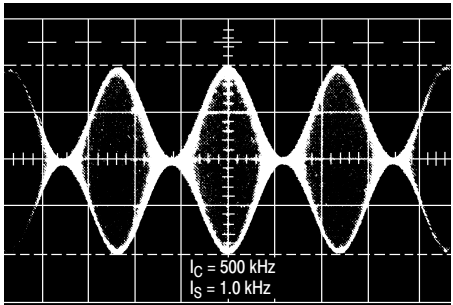


Figure 3. Amplitude Modulation Output Waveform

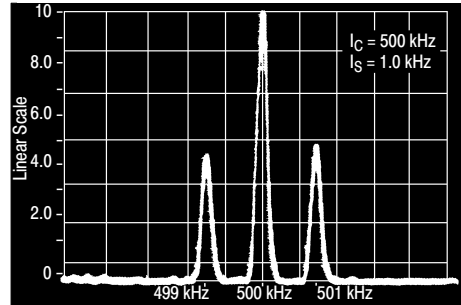


Figure 4. Amplitude-Modulation Spectrum

## MAXIMUM RATINGS ( $T_A = 25^\circ\text{C}$ , unless otherwise noted.)

Rating		Symbol	Value	Unit
Applied Voltage (V6-V8, V10-V1, V12-V8, V12-V10, V8-V4, V8-V1, V10-V4, V6-V10, V2-V5, V3-V5)		$\Delta V$	30	Vdc
Differential Input Signal		V8 - V10 V4 - V1	+5.0 $\pm(5 + I_5 R_e)$	Vdc
Maximum Bias Current		$I_5$	10	mA
Thermal Resistance, Junction-to-Air Plastic Dual In-Line Package		$R_{\theta JA}$	100	$^\circ\text{C}/\text{W}$
Operating Ambient Temperature Range		$T_A$	0 to +70 -40 to +125	$^\circ\text{C}$
Storage Temperature Range		$T_{stg}$	-65 to +150	$^\circ\text{C}$
Electrostatic Discharge Sensitivity (ESD) Human Body Model (HBM) Machine Model (MM)		ESD	2000 400	V

Stresses exceeding Maximum Ratings may damage the device. Maximum Ratings are stress ratings only. Functional operation above the Recommended Operating Conditions is not implied. Extended exposure to stresses above the Recommended Operating Conditions may affect device reliability.

# MC1496, MC1496B

**ELECTRICAL CHARACTERISTICS** ( $V_{CC} = 12$  Vdc,  $V_{EE} = -8.0$  Vdc,  $I_S = 1.0$  mAdc,  $R_L = 3.9$  k $\Omega$ ,  $R_e = 1.0$  k $\Omega$ ,  $T_A = T_{low}$  to  $T_{high}$ , all input and output characteristics are single-ended, unless otherwise noted.) (Note 1)

Characteristic	Fig.	Note	Symbol	Min	Typ	Max	Unit
Carrier Feedthrough $V_C = 60$ mVrms sine wave and offset adjusted to zero $V_C = 300$ mVpp square wave: offset adjusted to zero offset not adjusted	5	1	$V_{CFT}$	- - -	40 140 0.04 20	- - 0.4 200	$\mu$ Vrms  mVrms
Carrier Suppression $f_S = 10$ kHz, 300 mVrms $f_C = 500$ kHz, 60 mVrms sine wave $f_C = 10$ MHz, 60 mVrms sine wave	5	2	$V_{CS}$	40 -	65 50	- -	dB  k
Transadmittance Bandwidth (Magnitude) ( $R_L = 50$ $\Omega$ ) Carrier Input Port, $V_C = 60$ mVrms sine wave $f_S = 1.0$ kHz, 300 mVrms sine wave Signal Input Port, $V_S = 300$ mVrms sine wave $ V_C  = 0.5$ Vdc	8	8	$BW_{3dB}$	- -	300 80	- -	MHz
Signal Gain ( $V_S = 100$ mVrms, $f = 1.0$ kHz; $ V_C  = 0.5$ Vdc)	10	3	$A_{VS}$	2.5	3.5	-	V/V
Single-Ended Input Impedance, Signal Port, $f = 5.0$ MHz Parallel Input Resistance Parallel Input Capacitance	6	-	$r_{ip}$ $C_{ip}$	- -	200 2.0	- -	k $\Omega$ pF
Single-Ended Output Impedance, $f = 10$ MHz Parallel Output Resistance Parallel Output Capacitance	6	-	$r_{op}$ $C_{oo}$	- -	40 5.0	- -	k $\Omega$ pF
Input Bias Current $I_{bS} = \frac{I_1 + I_4}{2}$ ; $I_{bC} = \frac{I_8 + I_{10}}{2}$	7	-	$I_{bS}$ $I_{bC}$	- -	12 12	30 30	$\mu$ A
Input Offset Current $I_{ioS} = I_1 - I_4$ ; $I_{ioC} = I_8 - I_{10}$	7	-	$ I_{ioS} $ $ I_{ioC} $	- -	0.7 0.7	7.0 7.0	$\mu$ A
Average Temperature Coefficient of Input Offset Current ( $T_A = -55^\circ\text{C}$ to $+125^\circ\text{C}$ )	7	-	$ TC_{Iio} $	-	2.0	-	nA/ $^\circ\text{C}$
Output Offset Current (I6-I9)	7	-	$ I_{oo} $	-	14	80	$\mu$ A
Average Temperature Coefficient of Output Offset Current ( $T_A = -55^\circ\text{C}$ to $+125^\circ\text{C}$ )	7	-	$ TC_{Ioo} $	-	90	-	nA/ $^\circ\text{C}$
Common-Mode Input Swing, Signal Port, $f_S = 1.0$ kHz	9	4	CMV	-	5.0	-	Vpp
Common-Mode Gain, Signal Port, $f_S = 1.0$ kHz, $ V_C  = 0.5$ Vdc	9	-	ACM	-	-85	-	dB
Common-Mode Quiescent Output Voltage (Pin 6 or Pin 9)	10	-	$V_{out}$	-	8.0	-	Vpp
Differential Output Voltage Swing Capability	10	-	$V_{out}$	-	8.0	-	Vpp
Power Supply Current I6 + I12 I14	7	6	$I_{CC}$ $I_{EE}$	- -	2.0 3.0	4.0 5.0	mAdc
DC Power Dissipation	7	5	$P_D$	-	33	-	mW

1.  $T_{low} = 0^\circ\text{C}$  for MC1496       $T_{high} = +70^\circ\text{C}$  for MC1496  
       $= -40^\circ\text{C}$  for MC1496B       $= +125^\circ\text{C}$  for MC1496B

GENERAL OPERATING INFORMATION

**Carrier Feedthrough**

Carrier feedthrough is defined as the output voltage at carrier frequency with only the carrier applied (signal voltage = 0).

Carrier null is achieved by balancing the currents in the differential amplifier by means of a bias trim potentiometer (R1 of Figure 5).

**Carrier Suppression**

Carrier suppression is defined as the ratio of each sideband output to carrier output for the carrier and signal voltage levels specified.

Carrier suppression is very dependent on carrier input level, as shown in Figure 22. A low value of the carrier does not fully switch the upper switching devices, and results in lower signal gain, hence lower carrier suppression. A higher than optimum carrier level results in unnecessary device and circuit carrier feedthrough, which again degenerates the suppression figure. The MC1496 has been characterized with a 60 mVrms sinewave carrier input signal. This level provides optimum carrier suppression at carrier frequencies in the vicinity of 500 kHz, and is generally recommended for balanced modulator applications.

Carrier feedthrough is independent of signal level,  $V_S$ . Thus carrier suppression can be maximized by operating with large signal levels. However, a linear operating mode must be maintained in the signal-input transistor pair — for harmonics of the modulating signal will be generated and appear in the device output as spurious sidebands of the suppressed carrier. This requirement places an upper limit on input-signal amplitude (see Figure 20). Note also that an optimum carrier level is recommended in Figure 22 for good carrier suppression and minimum spurious sideband generation.

At higher frequencies circuit layout is very important in order to minimize carrier feedthrough. Shielding may be necessary in order to prevent capacitive coupling between the carrier input leads and the output leads.

**Signal Gain and Maximum Input Level**

Signal gain (single-ended) at low frequencies is defined as the voltage gain,

$$A_{VS} = \frac{V_o}{V_S} = \frac{R_L}{R_E + 2r_e} \text{ where } r_e = \frac{26 \text{ mV}}{I_5(\text{mA})}$$

A constant dc potential is applied to the carrier input terminals to fully switch two of the upper transistors “on” and two transistors “off” ( $V_C = 0.5 \text{ Vdc}$ ). This in effect forms a cascode differential amplifier.

Linear operation requires that the signal input be below a critical value determined by  $R_E$  and the bias current  $I_5$ .

$$V_S \leq I_5 R_E \text{ (Volts peak)}$$

Note that in the test circuit of Figure 10,  $V_S$  corresponds to a maximum value of 1.0 V peak.

**Common Mode Swing**

The common-mode swing is the voltage which may be applied to both bases of the signal differential amplifier, without saturating the current sources or without saturating the differential amplifier itself by swinging it into the upper switching devices. This swing is variable depending on the particular circuit and biasing conditions chosen.

**Power Dissipation**

Power dissipation,  $P_D$ , within the integrated circuit package should be calculated as the summation of the voltage-current products at each port, i.e. assuming  $V_{12} = V_6$ ,  $I_5 = I_6 = I_{12}$  and ignoring base current,  $P_D = 2 I_5 (V_6 - V_{14}) + I_5 V_5 - V_{14}$  where subscripts refer to pin numbers.

**Design Equations**

The following is a partial list of design equations needed to operate the circuit with other supply voltages and input conditions.

**A. Operating Current**

The internal bias currents are set by the conditions at Pin 5. Assume:

$$I_5 = I_6 = I_{12}, \\ I_B \ll I_C \text{ for all transistors}$$

then :

$$R_5 = \frac{V - \phi}{I_5} - 500 \Omega \quad \text{where: } R_5 \text{ is the resistor between Pin 5 and ground} \\ \phi = 0.75 \text{ at } T_A = +25^\circ\text{C}$$

The MC1496 has been characterized for the condition  $I_5 = 1.0 \text{ mA}$  and is the generally recommended value.

**B. Common-Mode Quiescent Output Voltage**

$$V_6 = V_{12} = V_+ - I_5 R_L$$

**Biasing**

The MC1496 requires three dc bias voltage levels which must be set externally. Guidelines for setting up these three levels include maintaining at least 2.0 V collector-base bias on all transistors while not exceeding the voltages given in the absolute maximum rating table;

$$30 \text{ Vdc} \geq [(V_6, V_{12}) - (V_8, V_{10})] \geq 2 \text{ Vdc} \\ 30 \text{ Vdc} \geq [(V_8, V_{10}) - (V_1, V_4)] \geq 2.7 \text{ Vdc} \\ 30 \text{ Vdc} \geq [(V_1, V_4) - (V_5)] \geq 2.7 \text{ Vdc}$$

The foregoing conditions are based on the following approximations:

$$V_6 = V_{12}, V_8 = V_{10}, V_1 = V_4$$

# MC1496, MC1496B

Bias currents flowing into Pins 1, 4, 8 and 10 are transistor base currents and can normally be neglected if external bias dividers are designed to carry 1.0 mA or more.

## Transadmittance Bandwidth

Carrier transadmittance bandwidth is the 3.0 dB bandwidth of the device forward transadmittance as defined by:

$$\gamma_{21C} = \frac{i_o \text{ (each sideband)}}{v_s \text{ (signal)}} \Big|_{V_o = 0}$$

Signal transadmittance bandwidth is the 3.0 dB bandwidth of the device forward transadmittance as defined by:

$$\gamma_{21S} = \frac{i_o \text{ (signal)}}{v_s \text{ (signal)}} \Big|_{V_c = 0.5 \text{ Vdc}, V_o = 0}$$

## Coupling and Bypass Capacitors

Capacitors C1 and C2 (Figure 5) should be selected for a reactance of less than 5.0 Ω at the carrier frequency.

## Output Signal

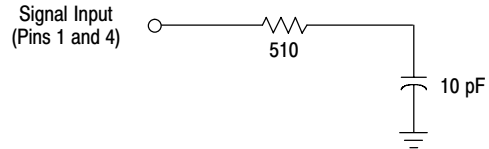
The output signal is taken from Pins 6 and 12 either balanced or single-ended. Figure 11 shows the output levels of each of the two output sidebands resulting from variations in both the carrier and modulating signal inputs with a single-ended output connection.

## Negative Supply

V<sub>EE</sub> should be dc only. The insertion of an RF choke in series with V<sub>EE</sub> can enhance the stability of the internal current sources.

## Signal Port Stability

Under certain values of driving source impedance, oscillation may occur. In this event, an RC suppression network should be connected directly to each input using short leads. This will reduce the Q of the source-tuned circuits that cause the oscillation.



An alternate method for low-frequency applications is to insert a 1.0 kΩ resistor in series with the input (Pins 1, 4). In this case input current drift may cause serious degradation of carrier suppression.

## TEST CIRCUITS

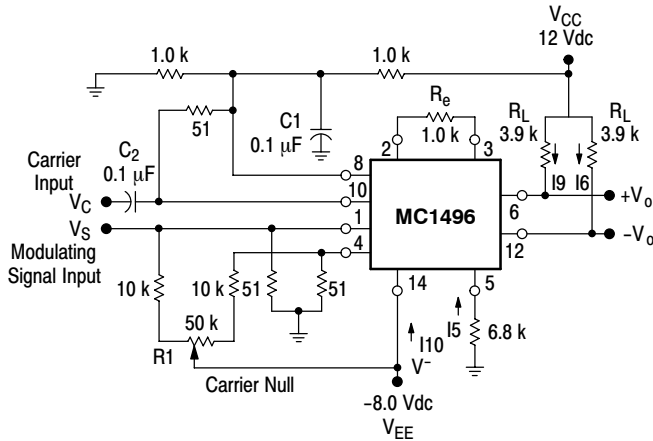
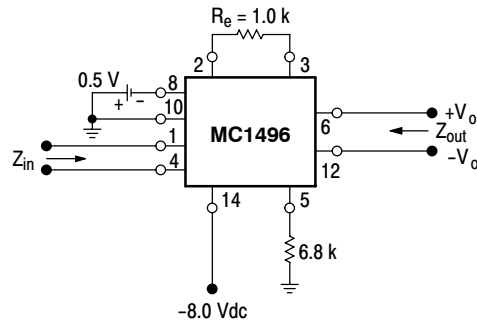


Figure 5. Carrier Rejection and Suppression



NOTE: Shielding of input and output leads may be needed to properly perform these tests.

Figure 6. Input-Output Impedance

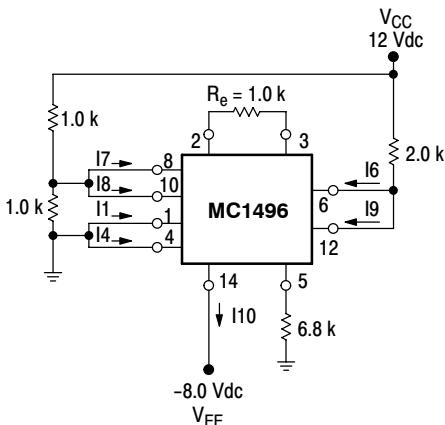


Figure 7. Bias and Offset Currents

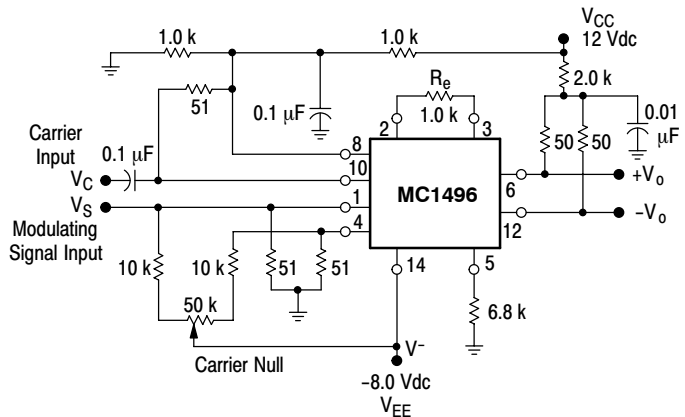


Figure 8. Transconductance Bandwidth

# MC1496, MC1496B

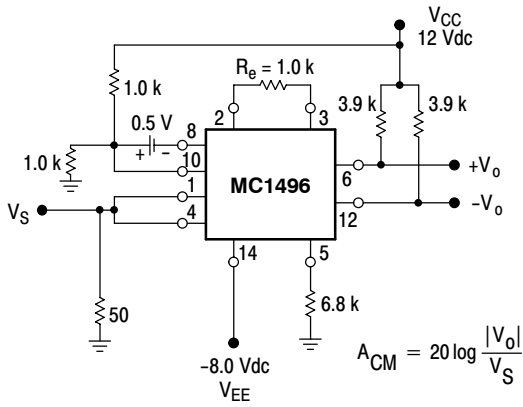


Figure 9. Common Mode Gain

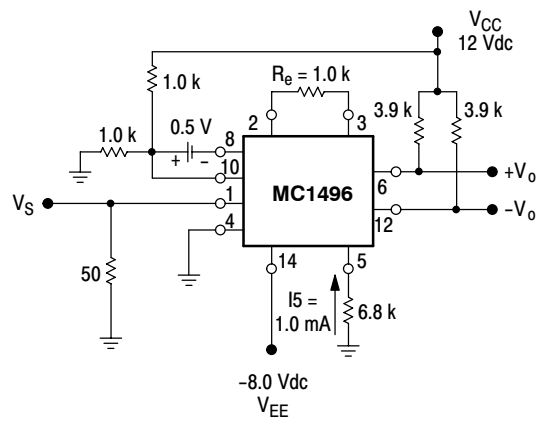


Figure 10. Signal Gain and Output Swing

## TYPICAL CHARACTERISTICS

Typical characteristics were obtained with circuit shown in Figure 5,  $f_C = 500$  kHz (sine wave),  $V_C = 60$  mVrms,  $f_S = 1.0$  kHz,  $V_S = 300$  mVrms,  $T_A = 25^\circ\text{C}$ , unless otherwise noted.

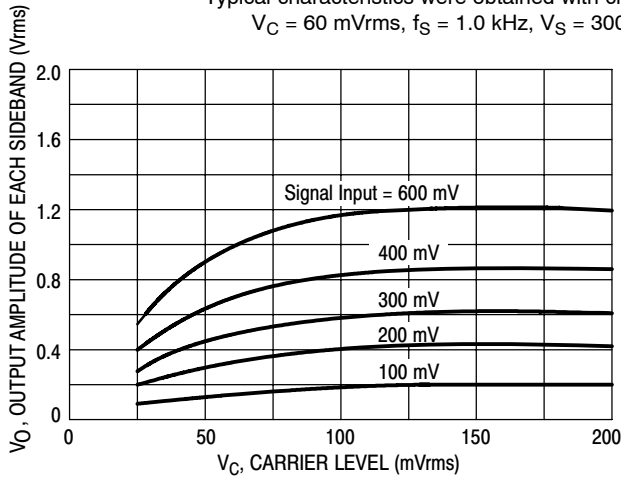


Figure 11. Sideband Output versus Carrier Levels

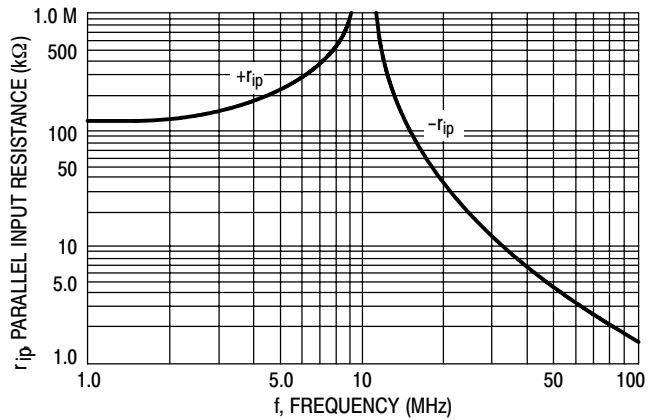


Figure 12. Signal-Port Parallel-Equivalent Input Resistance versus Frequency

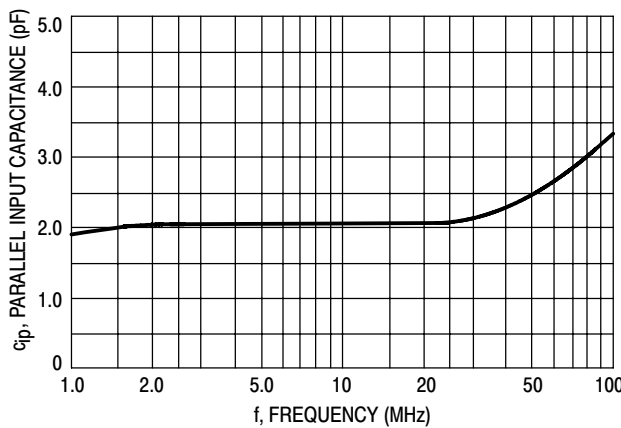


Figure 13. Signal-Port Parallel-Equivalent Input Capacitance versus Frequency

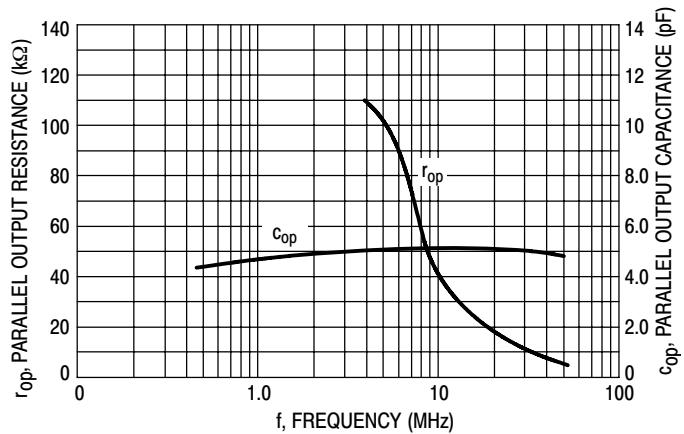
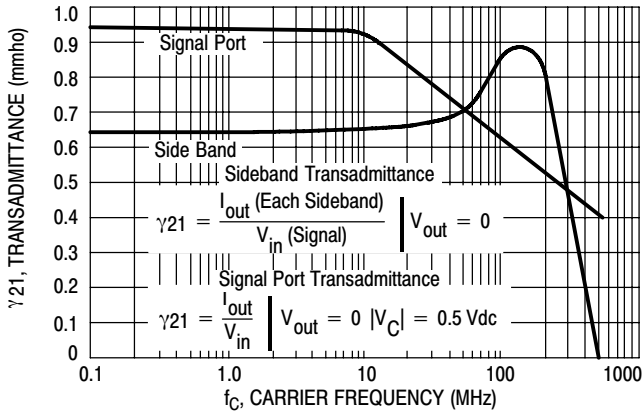


Figure 14. Single-Ended Output Impedance versus Frequency

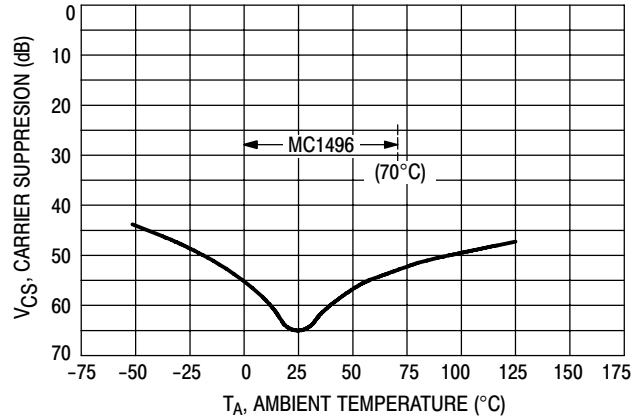
# MC1496, MC1496B

## TYPICAL CHARACTERISTICS (continued)

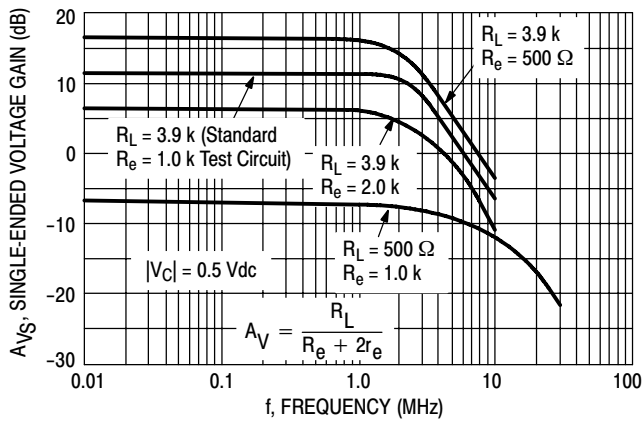
Typical characteristics were obtained with circuit shown in Figure 5,  $f_C = 500$  kHz (sine wave),  $V_C = 60$  mVrms,  $f_S = 1.0$  kHz,  $V_S = 300$  mVrms,  $T_A = 25^\circ\text{C}$ , unless otherwise noted.



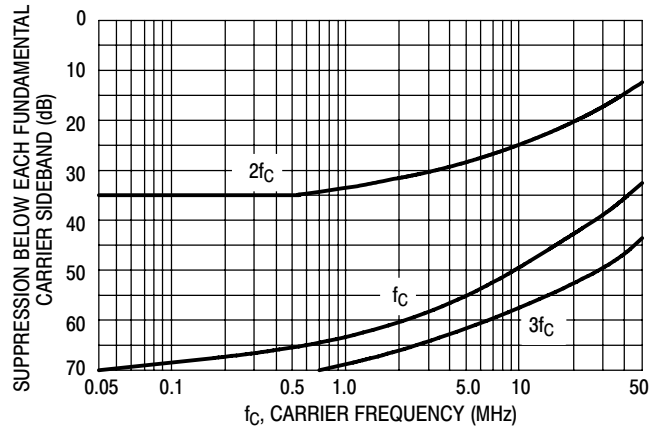
**Figure 15. Sideband and Signal Port Transadmittances versus Frequency**



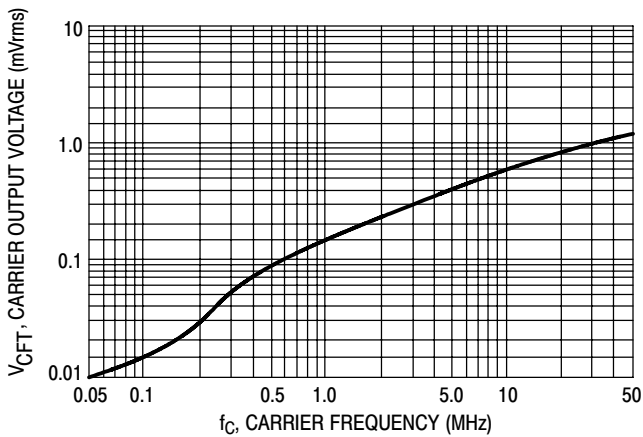
**Figure 16. Carrier Suppression versus Temperature**



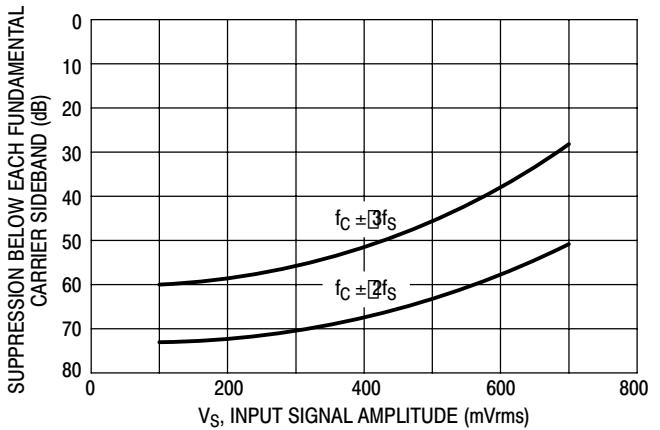
**Figure 17. Signal-Port Frequency Response**



**Figure 18. Carrier Suppression versus Frequency**

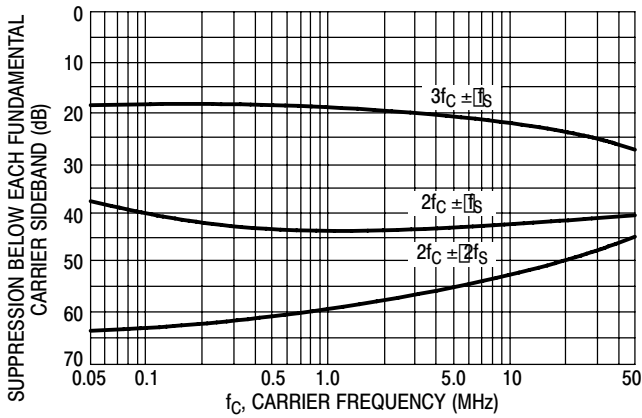


**Figure 19. Carrier Feedthrough versus Frequency**

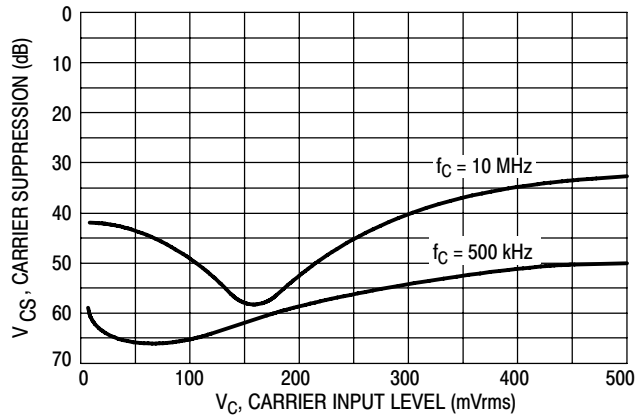


**Figure 20. Sideband Harmonic Suppression versus Input Signal Level**

# MC1496, MC1496B



**Figure 21. Suppression of Carrier Harmonic Sidebands versus Carrier Frequency**



**Figure 22. Carrier Suppression versus Carrier Input Level**

## OPERATIONS INFORMATION

The MC1496, a monolithic balanced modulator circuit, is shown in Figure 23.

This circuit consists of an upper quad differential amplifier driven by a standard differential amplifier with dual current sources. The output collectors are cross-coupled so that full-wave balanced multiplication of the two input voltages occurs. That is, the output signal is a constant times the product of the two input signals.

Mathematical analysis of linear ac signal multiplication indicates that the output spectrum will consist of only the sum and difference of the two input frequencies. Thus, the device may be used as a balanced modulator, doubly balanced mixer, product detector, frequency doubler, and other applications requiring these particular output signal characteristics.

The lower differential amplifier has its emitters connected to the package pins so that an external emitter resistance may be used. Also, external load resistors are employed at the device output.

### Signal Levels

The upper quad differential amplifier may be operated either in a linear or a saturated mode. The lower differential amplifier is operated in a linear mode for most applications.

For low-level operation at both input ports, the output signal will contain sum and difference frequency

components and have an amplitude which is a function of the product of the input signal amplitudes.

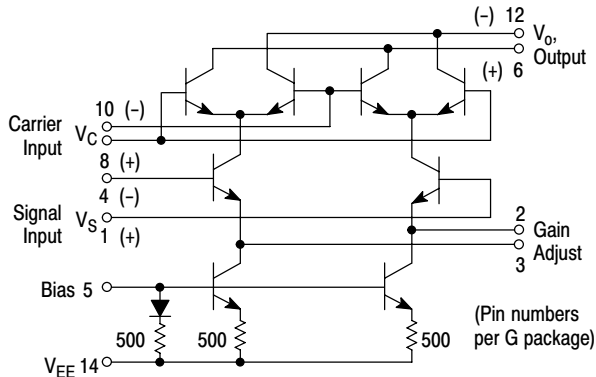
For high-level operation at the carrier input port and linear operation at the modulating signal port, the output signal will contain sum and difference frequency components of the modulating signal frequency and the fundamental and odd harmonics of the carrier frequency. The output amplitude will be a constant times the modulating signal amplitude. Any amplitude variations in the carrier signal will not appear in the output.

The linear signal handling capabilities of a differential amplifier are well defined. With no emitter degeneration, the maximum input voltage for linear operation is approximately 25 mV peak. Since the upper differential amplifier has its emitters internally connected, this voltage applies to the carrier input port for all conditions.

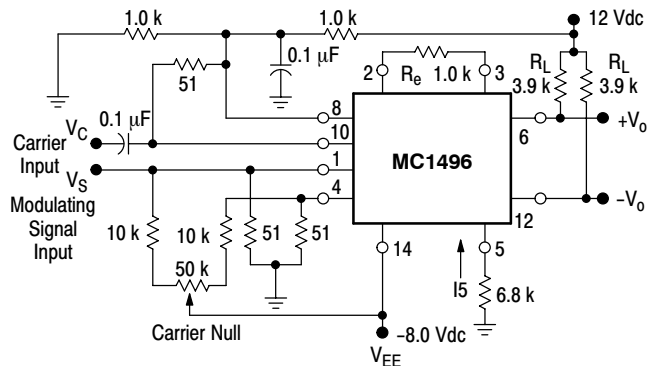
Since the lower differential amplifier has provisions for an external emitter resistance, its linear signal handling range may be adjusted by the user. The maximum input voltage for linear operation may be approximated from the following expression:

$$V = (15) (R_E) \text{ volts peak.}$$

This expression may be used to compute the minimum value of  $R_E$  for a given input voltage amplitude.



**Figure 23. Circuit Schematic**



**Figure 24. Typical Modulator Circuit**



Table 1. Voltage Gain and Output Frequencies

Carrier Input Signal (V <sub>C</sub> )	Approximate Voltage Gain	Output Signal Frequency(s)
Low-level dc	$\frac{R_L V_C}{2(R_E + 2r_e) \left(\frac{KT}{q}\right)}$	f <sub>M</sub>
High-level dc	$\frac{R_L}{R_E + 2r_e}$	f <sub>M</sub>
Low-level ac	$\frac{R_L V_C(\text{rms})}{2\sqrt{2} \left(\frac{KT}{q}\right) (R_E + 2r_e)}$	f <sub>C</sub> ± f <sub>M</sub>
High-level ac	$\frac{0.637 R_L}{R_E + 2r_e}$	f <sub>C</sub> ± f <sub>M</sub> , 3f <sub>C</sub> ± f <sub>M</sub> , 5f <sub>C</sub> ± f <sub>M</sub> , . . .

- Low-level Modulating Signal, V<sub>M</sub>, assumed in all cases. V<sub>C</sub> is Carrier Input Voltage.
- When the output signal contains multiple frequencies, the gain expression given is for the output amplitude of each of the two desired outputs, f<sub>C</sub> + f<sub>M</sub> and f<sub>C</sub> - f<sub>M</sub>.
- All gain expressions are for a single-ended output. For a differential output connection, multiply each expression by two.
- R<sub>L</sub> = Load resistance.
- R<sub>E</sub> = Emitter resistance between Pins 2 and 3.
- r<sub>e</sub> = Transistor dynamic emitter resistance, at 25°C;  $r_e \approx \frac{26 \text{ mV}}{I_5 (\text{mA})}$
- K = Boltzmann's Constant, T = temperature in degrees Kelvin, q = the charge on an electron.

The gain from the modulating signal input port to the output is the MC1496 gain parameter which is most often of interest to the designer. This gain has significance only when the lower differential amplifier is operated in a linear mode, but this includes most applications of the device.

As previously mentioned, the upper quad differential amplifier may be operated either in a linear or a saturated mode. Approximate gain expressions have been developed for the MC1496 for a low-level modulating signal input and the following carrier input conditions:

- Low-level dc
- High-level dc
- Low-level ac
- High-level ac

These gains are summarized in Table 1, along with the frequency components contained in the output signal.

**APPLICATIONS INFORMATION**

Double sideband suppressed carrier modulation is the basic application of the MC1496. The suggested circuit for this application is shown on the front page of this data sheet.

In some applications, it may be necessary to operate the MC1496 with a single dc supply voltage instead of dual supplies. Figure 25 shows a balanced modulator designed for operation with a single 12 Vdc supply. Performance of this circuit is similar to that of the dual supply modulator.

**AM Modulator**

The circuit shown in Figure 26 may be used as an amplitude modulator with a minor modification.

All that is required to shift from suppressed carrier to AM operation is to adjust the carrier null potentiometer for the proper amount of carrier insertion in the output signal.

However, the suppressed carrier null circuitry as shown in Figure 26 does not have sufficient adjustment range. Therefore, the modulator may be modified for AM operation by changing two resistor values in the null circuit as shown in Figure 27.

**Product Detector**

The MC1496 makes an excellent SSB product detector (see Figure 28).

This product detector has a sensitivity of 3.0 μV and a dynamic range of 90 dB when operating at an intermediate frequency of 9.0 MHz.

The detector is broadband for the entire high frequency range. For operation at very low intermediate frequencies down to 50 kHz the 0.1 μF capacitors on Pins 8 and 10 should be increased to 1.0 μF. Also, the output filter at Pin 12 can be tailored to a specific intermediate frequency and audio amplifier input impedance.

As in all applications of the MC1496, the emitter resistance between Pins 2 and 3 may be increased or decreased to adjust circuit gain, sensitivity, and dynamic range.

This circuit may also be used as an AM detector by introducing carrier signal at the carrier input and an AM signal at the SSB input.

The carrier signal may be derived from the intermediate frequency signal or generated locally. The carrier signal may

## MC1496, MC1496B

be introduced with or without modulation, provided its level is sufficiently high to saturate the upper quad differential amplifier. If the carrier signal is modulated, a 300 mVrms input level is recommended.

### Doubly Balanced Mixer

The MC1496 may be used as a doubly balanced mixer with either broadband or tuned narrow band input and output networks.

The local oscillator signal is introduced at the carrier input port with a recommended amplitude of 100 mVrms.

Figure 29 shows a mixer with a broadband input and a tuned output.

### Frequency Doubler

The MC1496 will operate as a frequency doubler by introducing the same frequency at both input ports.

Figures 30 and 31 show a broadband frequency doubler and a tuned output very high frequency (VHF) doubler, respectively.

### Phase Detection and FM Detection

The MC1496 will function as a phase detector. High-level input signals are introduced at both inputs. When both inputs are at the same frequency the MC1496 will deliver an output which is a function of the phase difference between the two input signals.

An FM detector may be constructed by using the phase detector principle. A tuned circuit is added at one of the inputs to cause the two input signals to vary in phase as a function of frequency. The MC1496 will then provide an output which is a function of the input signal frequency.

## TYPICAL APPLICATIONS

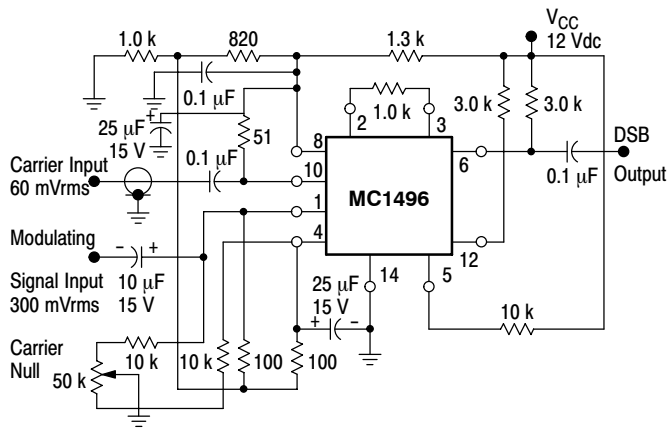


Figure 25. Balanced Modulator (12 Vdc Single Supply)

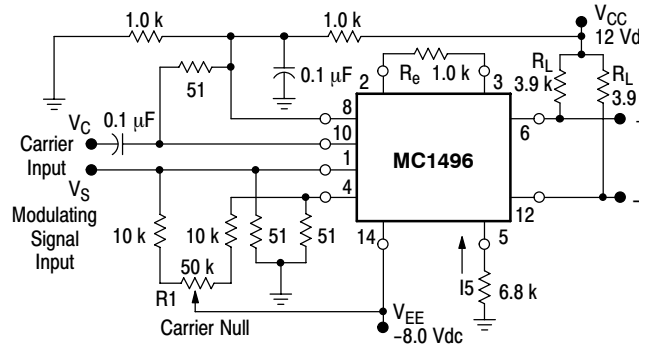


Figure 26. Balanced Modulator-Demodulator

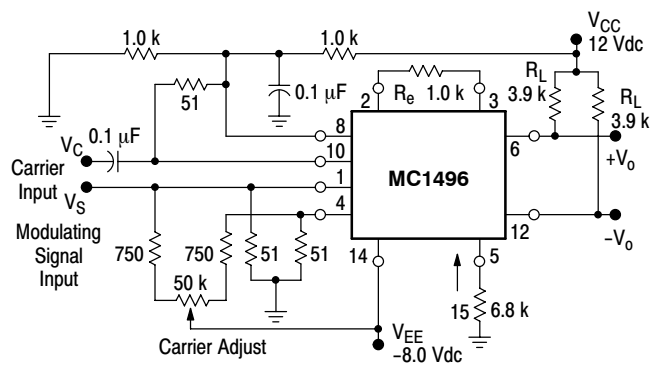


Figure 27. AM Modulator Circuit

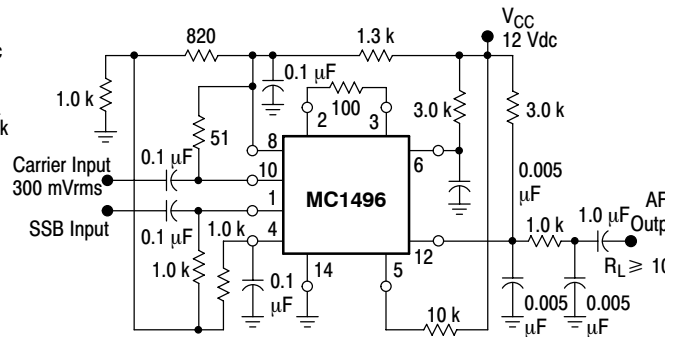
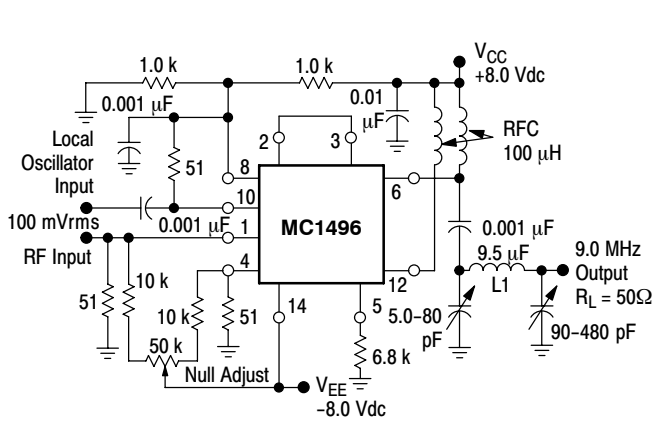


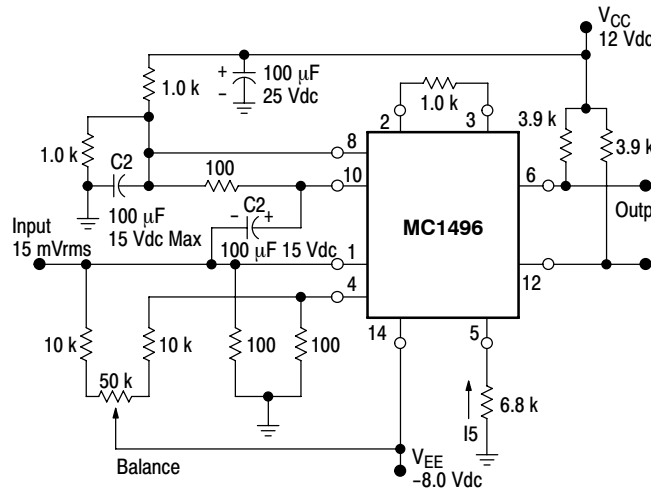
Figure 28. Product Detector (12 Vdc Single Supply)

# MC1496, MC1496B

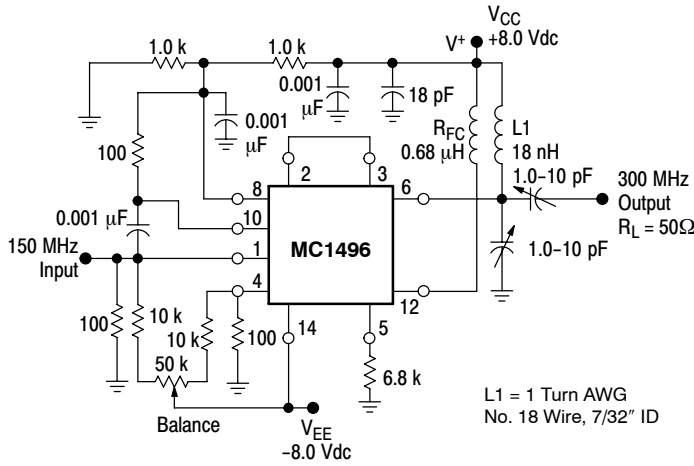


L1 = 44 Turns AWG No. 28 Enameled Wire, Wound on Micrometals Type 44-6 Toroid Core.

**Figure 29. Doubly Balanced Mixer (Broadband Inputs, 9.0 MHz Tuned Output)**

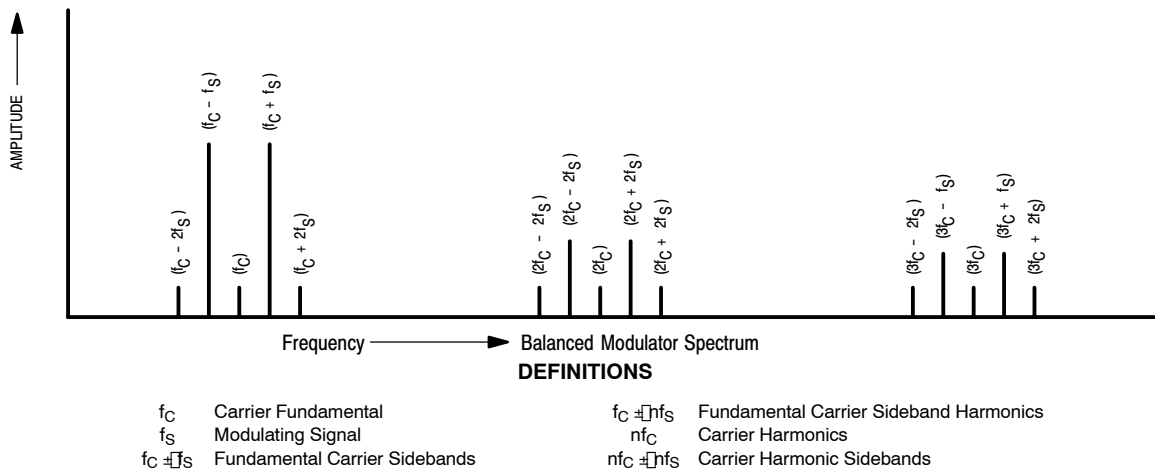


**Figure 30. Low-Frequency Doubler**



L1 = 1 Turn AWG No. 18 Wire, 7/32" ID

**Figure 31. 150 to 300 MHz Doubler**



# MC1496, MC1496B

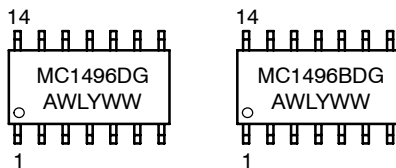
## ORDERING INFORMATION

Device	Package	Shipping†
MC1496D	SOIC-14	55 Units/Rail
MC1496DG	SOIC-14 (Pb-Free)	
MC1496DR2	SOIC-14	2500 Tape & Reel
MC1496DR2G	SOIC-14 (Pb-Free)	
MC1496P	PDIP-14	25 Units/Rail
MC1496PG	PDIP-14 (Pb-Free)	
MC1496P1	PDIP-14	
MC1496P1G	PDIP-14 (Pb-Free)	
MC1496BD	SOIC-14	55 Units/Rail
MC1496BDG	SOIC-14 (Pb-Free)	
MC1496BDR2	SOIC-14	2500 Tape & Reel
MC1496BDR2G	SOIC-14 (Pb-Free)	
MC1496BP	PDIP-14	25 Units/Rail
MC1496BPG	PDIP-14 (Pb-Free)	

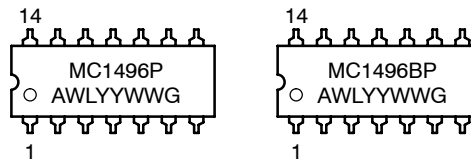
†For information on tape and reel specifications, including part orientation and tape sizes, please refer to our Tape and Reel Packaging Specifications Brochure, BRD8011/D.

## MARKING DIAGRAMS

**SOIC-14  
D SUFFIX  
CASE 751A**



**PDIP-14  
P SUFFIX  
CASE 646**

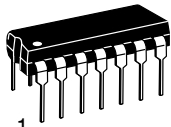


A = Assembly Location  
 WL = Wafer Lot  
 YY, Y = Year  
 WW = Work Week  
 G = Pb-Free Package

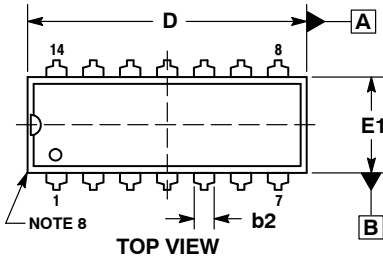
# MECHANICAL CASE OUTLINE

## PACKAGE DIMENSIONS

ON Semiconductor®

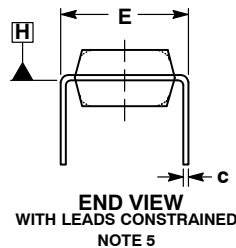


SCALE 1:1



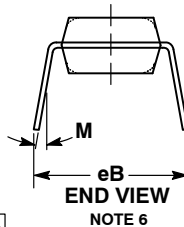
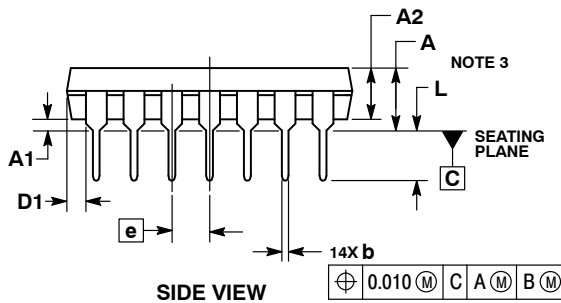
PDIP-14  
CASE 646-06  
ISSUE S

DATE 22 APR 2015



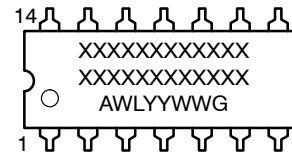
NOTES:

1. DIMENSIONING AND TOLERANCING PER ASME Y14.5M, 1994.
2. CONTROLLING DIMENSION: INCHES.
3. DIMENSIONS A, A1 AND L ARE MEASURED WITH THE PACKAGE SEATED IN JEDEC SEATING PLANE GAUGE GS-3.
4. DIMENSIONS D, D1 AND E1 DO NOT INCLUDE MOLD FLASH OR PROTRUSIONS. MOLD FLASH OR PROTRUSIONS ARE NOT TO EXCEED 0.10 INCH.
5. DIMENSION E IS MEASURED AT A POINT 0.015 BELOW DATUM PLANE H WITH THE LEADS CONSTRAINED PERPENDICULAR TO DATUM C.
6. DIMENSION eB IS MEASURED AT THE LEAD TIPS WITH THE LEADS UNCONSTRAINED.
7. DATUM PLANE H IS COINCIDENT WITH THE BOTTOM OF THE LEADS, WHERE THE LEADS EXIT THE BODY.
8. PACKAGE CONTOUR IS OPTIONAL (ROUNDED OR SQUARE CORNERS).



DIM	INCHES		MILLIMETERS	
	MIN	MAX	MIN	MAX
A	----	0.210	----	5.33
A1	0.015	----	0.38	----
A2	0.115	0.195	2.92	4.95
b	0.014	0.022	0.35	0.56
b2	0.060 TYP		1.52 TYP	
C	0.008	0.014	0.20	0.36
D	0.735	0.775	18.67	19.69
D1	0.005	----	0.13	----
E	0.300	0.325	7.62	8.26
E1	0.240	0.280	6.10	7.11
e	0.100 BSC		2.54 BSC	
eB	----	0.430	----	10.92
L	0.115	0.150	2.92	3.81
M	----	10°	----	10°

GENERIC MARKING DIAGRAM\*



- XXXXX = Specific Device Code
- A = Assembly Location
- WL = Wafer Lot
- YY = Year
- WW = Work Week
- G = Pb-Free Package

\*This information is generic. Please refer to device data sheet for actual part marking. Pb-Free indicator, "G" or microdot "▪", may or may not be present.

STYLES ON PAGE 2

<b>DOCUMENT NUMBER:</b>	<b>98ASB42428B</b>	Electronic versions are uncontrolled except when accessed directly from the Document Repository. Printed versions are uncontrolled except when stamped "CONTROLLED COPY" in red.
<b>DESCRIPTION:</b>	<b>PDIP-14</b>	<b>PAGE 1 OF 2</b>

ON Semiconductor and are trademarks of Semiconductor Components Industries, LLC dba ON Semiconductor or its subsidiaries in the United States and/or other countries. ON Semiconductor reserves the right to make changes without further notice to any products herein. ON Semiconductor makes no warranty, representation or guarantee regarding the suitability of its products for any particular purpose, nor does ON Semiconductor assume any liability arising out of the application or use of any product or circuit, and specifically disclaims any and all liability, including without limitation special, consequential or incidental damages. ON Semiconductor does not convey any license under its patent rights nor the rights of others.

**PDIP-14**  
**CASE 646-06**  
**ISSUE S**

DATE 22 APR 2015

**STYLE 1:**  
 PIN 1. COLLECTOR  
 2. BASE  
 3. EMITTER  
 4. NO  
**CONNECTION**  
 5. EMITTER  
 6. BASE  
 7. COLLECTOR  
 8. COLLECTOR  
 9. BASE  
 10. EMITTER  
 11. NO  
**CONNECTION**  
 12. EMITTER  
 13. BASE  
 14. COLLECTOR

**STYLE 2:**  
 CANCELLED

**STYLE 3:**  
 CANCELLED

**STYLE 4:**  
 PIN 1. DRAIN  
 2. SOURCE  
 3. GATE  
 4. NO  
**CONNECTION**  
 5. GATE  
 6. SOURCE  
 7. DRAIN  
 8. DRAIN  
 9. SOURCE  
 10. GATE  
 11. NO  
**CONNECTION**  
 12. GATE  
 13. SOURCE  
 14. DRAIN

**STYLE 5:**  
 PIN 1. GATE  
 2. DRAIN  
 3. SOURCE  
 4. NO CONNECTION  
 5. SOURCE  
 6. DRAIN  
 7. GATE  
 8. GATE  
 9. DRAIN  
 10. SOURCE  
 11. NO CONNECTION  
 12. SOURCE  
 13. DRAIN  
 14. GATE

**STYLE 6:**  
 PIN 1. COMMON CATHODE  
 2. ANODE/CATHODE  
 3. ANODE/CATHODE  
 4. NO CONNECTION  
 5. ANODE/CATHODE  
 6. NO CONNECTION  
 7. ANODE/CATHODE  
 8. ANODE/CATHODE  
 9. ANODE/CATHODE  
 10. NO CONNECTION  
 11. ANODE/CATHODE  
 12. ANODE/CATHODE  
 13. NO CONNECTION  
 14. COMMON ANODE

**STYLE 7:**  
 PIN 1. NO CONNECTION  
 2. ANODE  
 3. ANODE  
 4. NO CONNECTION  
 5. ANODE  
 6. NO CONNECTION  
 7. ANODE  
 8. ANODE  
 9. ANODE  
 10. NO CONNECTION  
 11. ANODE  
 12. ANODE  
 13. NO CONNECTION  
 14. COMMON  
 CATHODE

**STYLE 8:**  
 PIN 1. NO CONNECTION  
 2. CATHODE  
 3. CATHODE  
 4. NO CONNECTION  
 5. CATHODE  
 6. NO CONNECTION  
 7. CATHODE  
 8. CATHODE  
 9. CATHODE  
 10. NO CONNECTION  
 11. CATHODE  
 12. CATHODE  
 13. NO CONNECTION  
 14. COMMON ANODE


**STYLE 9:**  
 PIN 1. COMMON CATHODE  
 2. ANODE/CATHODE  
 3. ANODE/CATHODE  
 4. NO CONNECTION  
 5. ANODE/CATHODE  
 6. ANODE/CATHODE  
 7. COMMON ANODE  
 8. COMMON ANODE  
 9. ANODE/CATHODE  
 10. ANODE/CATHODE  
 11. NO CONNECTION  
 12. ANODE/CATHODE  
 13. ANODE/CATHODE  
 14. COMMON CATHODE

**STYLE 10:**  
 PIN 1. COMMON  
 CATHODE  
 2. ANODE/CATHODE  
 3. ANODE/CATHODE  
 4. ANODE/CATHODE  
 5. ANODE/CATHODE  
 6. NO CONNECTION  
 7. COMMON ANODE  
 8. COMMON  
 CATHODE  
 9. ANODE/CATHODE  
 10. ANODE/CATHODE  
 11. ANODE/CATHODE  
 12. ANODE/CATHODE  
 13. NO CONNECTION  
 14. COMMON ANODE

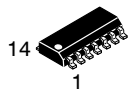
**STYLE 11:**  
 PIN 1. CATHODE  
 2. CATHODE  
 3. CATHODE  
 4. CATHODE  
 5. CATHODE  
 6. CATHODE  
 7. CATHODE  
 8. ANODE  
 9. ANODE  
 10. ANODE  
 11. ANODE  
 12. ANODE  
 13. ANODE  
 14. ANODE

**STYLE 12:**  
 PIN 1. COMMON CATHODE  
 2. COMMON ANODE  
 3. ANODE/CATHODE  
 4. ANODE/CATHODE  
 5. ANODE/CATHODE  
 6. COMMON ANODE  
 7. COMMON CATHODE  
 8. ANODE/CATHODE  
 9. ANODE/CATHODE  
 10. ANODE/CATHODE  
 11. ANODE/CATHODE  
 12. ANODE/CATHODE  
 13. ANODE/CATHODE  
 14. ANODE/CATHODE

<b>DOCUMENT NUMBER:</b>	<b>98ASB42428B</b>	Electronic versions are uncontrolled except when accessed directly from the Document Repository. Printed versions are uncontrolled except when stamped "CONTROLLED COPY" in red.
<b>DESCRIPTION:</b>	<b>PDIP-14</b>	<b>PAGE 2 OF 2</b>

ON Semiconductor and  are trademarks of Semiconductor Components Industries, LLC dba ON Semiconductor or its subsidiaries in the United States and/or other countries. ON Semiconductor reserves the right to make changes without further notice to any products herein. ON Semiconductor makes no warranty, representation or guarantee regarding the suitability of its products for any particular purpose, nor does ON Semiconductor assume any liability arising out of the application or use of any product or circuit, and specifically disclaims any and all liability, including without limitation special, consequential or incidental damages. ON Semiconductor does not convey any license under its patent rights nor the rights of others.

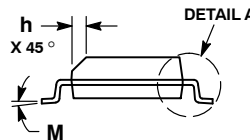
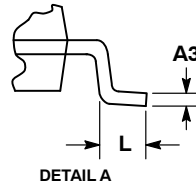
# MECHANICAL CASE OUTLINE PACKAGE DIMENSIONS



SCALE 1:1

SOIC-14 NB  
CASE 751A-03  
ISSUE L

DATE 03 FEB 2016



NOTES:

1. DIMENSIONING AND TOLERANCING PER ASME Y14.5M, 1994.
2. CONTROLLING DIMENSION: MILLIMETERS.
3. DIMENSION b DOES NOT INCLUDE DAMBAR PROTRUSION. ALLOWABLE PROTRUSION SHALL BE 0.13 TOTAL IN EXCESS OF AT MAXIMUM MATERIAL CONDITION.
4. DIMENSIONS D AND E DO NOT INCLUDE MOLD PROTRUSIONS.
5. MAXIMUM MOLD PROTRUSION 0.15 PER SIDE.

DIM	MILLIMETERS		INCHES	
	MIN	MAX	MIN	MAX
A	1.35	1.75	0.054	0.068
A1	0.10	0.25	0.004	0.010
A3	0.19	0.25	0.008	0.010
b	0.35	0.49	0.014	0.019
D	8.55	8.75	0.337	0.344
E	3.80	4.00	0.150	0.157
e	1.27 BSC		0.050 BSC	
H	5.80	6.20	0.228	0.244
h	0.25	0.50	0.010	0.019
L	0.40	1.25	0.016	0.049
M	0°	7°	0°	7°

SOLDERING FOOTPRINT\*



DIMENSIONS: MILLIMETERS

\*For additional information on our Pb-Free strategy and soldering details, please download the ON Semiconductor Soldering and Mounting Techniques Reference Manual, SOLDERRM/D.

GENERIC MARKING DIAGRAM\*



- XXXXXX = Specific Device Code
- A = Assembly Location
- WL = Wafer Lot
- Y = Year
- WW = Work Week
- G = Pb-Free Package

\*This information is generic. Please refer to device data sheet for actual part marking. Pb-Free indicator, "G" or microdot "▪", may or may not be present. Some products may not follow the Generic Marking.

STYLES ON PAGE 2

DOCUMENT NUMBER:	98ASB42565B	Electronic versions are uncontrolled except when accessed directly from the Document Repository. Printed versions are uncontrolled except when stamped "CONTROLLED COPY" in red.
DESCRIPTION:	SOIC-14 NB	PAGE 1 OF 2

onsemi and onsemi are trademarks of Semiconductor Components Industries, LLC dba onsemi or its subsidiaries in the United States and/or other countries. onsemi reserves the right to make changes without further notice to any products herein. onsemi makes no warranty, representation or guarantee regarding the suitability of its products for any particular purpose, nor does onsemi assume any liability arising out of the application or use of any product or circuit, and specifically disclaims any and all liability, including without limitation special, consequential or incidental damages. onsemi does not convey any license under its patent rights nor the rights of others.

**SOIC-14**  
**CASE 751A-03**  
**ISSUE L**

DATE 03 FEB 2016

STYLE 1:  
 PIN 1. COMMON CATHODE  
 2. ANODE/CATHODE  
 3. ANODE/CATHODE  
 4. NO CONNECTION  
 5. ANODE/CATHODE  
 6. NO CONNECTION  
 7. ANODE/CATHODE  
 8. ANODE/CATHODE  
 9. ANODE/CATHODE  
 10. NO CONNECTION  
 11. ANODE/CATHODE  
 12. ANODE/CATHODE  
 13. NO CONNECTION  
 14. COMMON ANODE

STYLE 2:  
 CANCELLED

STYLE 3:  
 PIN 1. NO CONNECTION  
 2. ANODE  
 3. ANODE  
 4. NO CONNECTION  
 5. ANODE  
 6. NO CONNECTION  
 7. ANODE  
 8. ANODE  
 9. ANODE  
 10. NO CONNECTION  
 11. ANODE  
 12. ANODE  
 13. NO CONNECTION  
 14. COMMON CATHODE

STYLE 4:  
 PIN 1. NO CONNECTION  
 2. CATHODE  
 3. CATHODE  
 4. NO CONNECTION  
 5. CATHODE  
 6. NO CONNECTION  
 7. CATHODE  
 8. CATHODE  
 9. CATHODE  
 10. NO CONNECTION  
 11. CATHODE  
 12. CATHODE  
 13. NO CONNECTION  
 14. COMMON ANODE

STYLE 5:  
 PIN 1. COMMON CATHODE  
 2. ANODE/CATHODE  
 3. ANODE/CATHODE  
 4. ANODE/CATHODE  
 5. ANODE/CATHODE  
 6. NO CONNECTION  
 7. COMMON ANODE  
 8. COMMON CATHODE  
 9. ANODE/CATHODE  
 10. ANODE/CATHODE  
 11. ANODE/CATHODE  
 12. ANODE/CATHODE  
 13. NO CONNECTION  
 14. COMMON ANODE

STYLE 6:  
 PIN 1. CATHODE  
 2. CATHODE  
 3. CATHODE  
 4. CATHODE  
 5. CATHODE  
 6. CATHODE  
 7. CATHODE  
 8. ANODE  
 9. ANODE  
 10. ANODE  
 11. ANODE  
 12. ANODE  
 13. ANODE  
 14. ANODE

STYLE 7:  
 PIN 1. ANODE/CATHODE  
 2. COMMON ANODE  
 3. COMMON CATHODE  
 4. ANODE/CATHODE  
 5. ANODE/CATHODE  
 6. ANODE/CATHODE  
 7. ANODE/CATHODE  
 8. ANODE/CATHODE  
 9. ANODE/CATHODE  
 10. ANODE/CATHODE  
 11. COMMON CATHODE  
 12. COMMON ANODE  
 13. ANODE/CATHODE  
 14. ANODE/CATHODE

STYLE 8:  
 PIN 1. COMMON CATHODE  
 2. ANODE/CATHODE  
 3. ANODE/CATHODE  
 4. NO CONNECTION  
 5. ANODE/CATHODE  
 6. ANODE/CATHODE  
 7. COMMON ANODE  
 8. COMMON ANODE  
 9. ANODE/CATHODE  
 10. ANODE/CATHODE  
 11. NO CONNECTION  
 12. ANODE/CATHODE  
 13. ANODE/CATHODE  
 14. COMMON CATHODE

<b>DOCUMENT NUMBER:</b>	<b>98ASB42565B</b>	Electronic versions are uncontrolled except when accessed directly from the Document Repository. Printed versions are uncontrolled except when stamped "CONTROLLED COPY" in red.
<b>DESCRIPTION:</b>	<b>SOIC-14 NB</b>	<b>PAGE 2 OF 2</b>

**onsemi** and **ONSEMI** are trademarks of Semiconductor Components Industries, LLC dba **onsemi** or its subsidiaries in the United States and/or other countries. **onsemi** reserves the right to make changes without further notice to any products herein. **onsemi** makes no warranty, representation or guarantee regarding the suitability of its products for any particular purpose, nor does **onsemi** assume any liability arising out of the application or use of any product or circuit, and specifically disclaims any and all liability, including without limitation special, consequential or incidental damages. **onsemi** does not convey any license under its patent rights nor the rights of others.



**onsemi**, **Onsemi**, and other names, marks, and brands are registered and/or common law trademarks of Semiconductor Components Industries, LLC dba "**onsemi**" or its affiliates and/or subsidiaries in the United States and/or other countries. **onsemi** owns the rights to a number of patents, trademarks, copyrights, trade secrets, and other intellectual property. A listing of **onsemi**'s product/patent coverage may be accessed at [www.onsemi.com/site/pdf/Patent-Marking.pdf](http://www.onsemi.com/site/pdf/Patent-Marking.pdf). **onsemi** reserves the right to make changes at any time to any products or information herein, without notice. The information herein is provided "as-is" and **onsemi** makes no warranty, representation or guarantee regarding the accuracy of the information, product features, availability, functionality, or suitability of its products for any particular purpose, nor does **onsemi** assume any liability arising out of the application or use of any product or circuit, and specifically disclaims any and all liability, including without limitation special, consequential or incidental damages. Buyer is responsible for its products and applications using **onsemi** products, including compliance with all laws, regulations and safety requirements or standards, regardless of any support or applications information provided by **onsemi**. "Typical" parameters which may be provided in **onsemi** data sheets and/or specifications can and do vary in different applications and actual performance may vary over time. All operating parameters, including "Typicals" must be validated for each customer application by customer's technical experts. **onsemi** does not convey any license under any of its intellectual property rights nor the rights of others. **onsemi** products are not designed, intended, or authorized for use as a critical component in life support systems or any FDA Class 3 medical devices or medical devices with a same or similar classification in a foreign jurisdiction or any devices intended for implantation in the human body. Should Buyer purchase or use **onsemi** products for any such unintended or unauthorized application, Buyer shall indemnify and hold **onsemi** and its officers, employees, subsidiaries, affiliates, and distributors harmless against all claims, costs, damages, and expenses, and reasonable attorney fees arising out of, directly or indirectly, any claim of personal injury or death associated with such unintended or unauthorized use, even if such claim alleges that **onsemi** was negligent regarding the design or manufacture of the part. **onsemi** is an Equal Opportunity/Affirmative Action Employer. This literature is subject to all applicable copyright laws and is not for resale in any manner.

## ADDITIONAL INFORMATION

### TECHNICAL PUBLICATIONS:

Technical Library: [www.onsemi.com/design/resources/technical-documentation](http://www.onsemi.com/design/resources/technical-documentation)  
onsemi Website: [www.onsemi.com](http://www.onsemi.com)

### ONLINE SUPPORT: [www.onsemi.com/support](http://www.onsemi.com/support)

For additional information, please contact your local Sales Representative at [www.onsemi.com/support/sales](http://www.onsemi.com/support/sales)