

Low-Voltage, 1 Ω SPDT Analog Switch with Power-Off Isolation

FSA4159

Description

The FSA4159 is a high-performance Single-Pole / Double-Throw (SPDT) analog switch. The device features ultra-low R_{ON} of 1 Ω at 4.5 V V_{CC} and operates over the wide V_{CC} range of 1.65 V to 5.50 V. The device is fabricated with sub-micron CMOS technology to achieve fast switching speeds and is designed for break-before-make operation.

The FSA4159 features very low quiescent current even when the control voltage is lower than the V_{CC} supply. This feature services mobile handset applications by allowing direct interface with baseband processor general-purpose I/Os.

Features

- Low I_{CC} when the S Input is Lower than V_{CC}
- Power-Off Isolation ($V_{CC} = 0$ V)
- 1 Ω On Resistance (R_{ON}) at 4.5 V V_{CC}
- 0.25 Ω Maximum R_{ON} Flatness for 4.5 V V_{CC}
- Space-Saving, Pb-Free, 6-Lead SC70 Surface Mount Package
- Broad V_{CC} Operating Range: 1.65 V to 5.50 V
- Fast Turn-On and Turn-Off Times
- Break-Before-Make Enable Circuitry
- These Devices are Pb-Free and are RoHS Compliant

Applications

- Cellular Phone
- Portable Media Player
- PDA

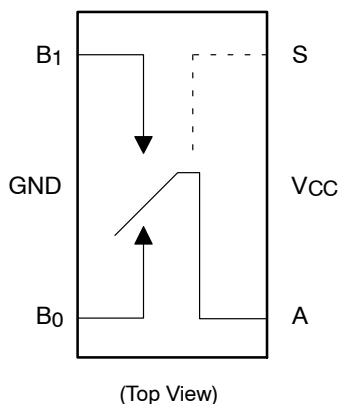
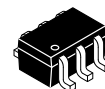

Figure 1. Analog Symbols



SC-88 (SC-70 6 Lead), 1.25x2
CASE 419AD



SIP6 1.45X1.0
CASE 127EB

MARKING DIAGRAMS

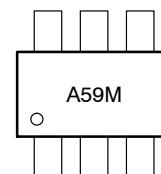

A59 = Specific Device Code
M = Assembly Operationmonth



FX = Specific Device Code (S2)
&K = 2-Digits Lot Run Traceability Code
&2 = 2-Digit Date Code
&Z = Assembly Plant Code

ORDERING INFORMATION

See detailed ordering and shipping information on page 2 of this data sheet.

FSA4159

ORDERING INFORMATION

Part Number	Operating Temperature Range	Top Mark	Package	Shipping [†]
FSA4159P6X	-40°C to +85°C	A59	SC-88 (SC-70 6 Lead), 1.25x2 (Pb-Free)	3000 / Tape & Reel
FSA4159L6X	-40°C to +85°C	S2	SIP6 1.45X1.0 (Pb-Free)	5000 / Tape & Reel

[†]For information on tape and reel specifications, including part orientation and tape sizes, please refer to our Tape and Reel Packaging Specifications Brochure, BRD8011/D.

PIN CONFIGURATION

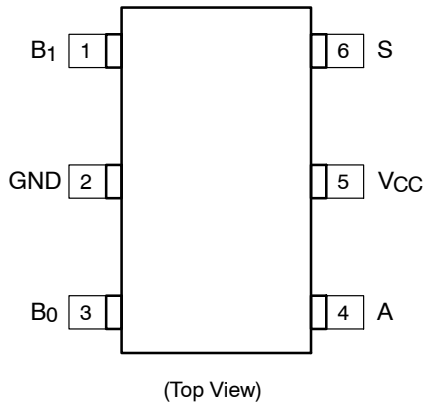

Figure 2. SC70 Pin Assignments

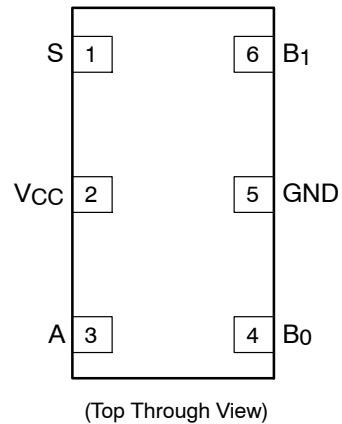

Figure 3. MicroPak™ Pin Assignments

PIN DEFINITIONS

Pin# SC70	Pin# MicroPak	Name	Description
1	6	B1	Data Ports
2	5	GND	Ground
3	4	B0	Data Ports
4	3	A	Data Ports
5	2	V _{CC}	Supply Voltage
6	1	S	Control Input

TRUTH TABLE

Control Input (S)	Function
Low	B0 connected to A
High	B1 connected to A

FSA4159

ABSOLUTE MAXIMUM RATINGS

Symbol	Parameter	Min	Max	Unit
V _{CC}	Supply Voltage	-0.5	6.5	V
V _{SW}	Switch Voltage (Note 1)	-0.5	V _{CC} + 0.5	V
V _{IN}	Input Voltage (Note 1)	-0.5	6.5	V
I _{IK}	Input Diode Current		-50	mA
I _{SW}	Switch Current (Continuous)		200	mA
I _{SWPEAK}	Peak Switch Current (Pulsed at 1 ms Duration, < 10% Duty Cycle)		400	mA
P _D	Power Dissipation at 85°C		180	mW
T _{STG}	Storage Temperature Range	-65	+150	°C
T _J	Maximum Junction Temperature		+150	°C
T _L	Lead Temperature (Soldering, 10 seconds)		+260	°C
ESD	Electrostatic Discharge Capability	Human Body Model (JEDEC: JESD22-A114)	4000	V
		Charged Device Model (JEDEC: JESD22-C101)	1500	
		Machine Model (JEDEC: JESD22-A115)	200	

Stresses exceeding those listed in the Maximum Ratings table may damage the device. If any of these limits are exceeded, device functionality should not be assumed, damage may occur and reliability may be affected.

1. The input and output negative ratings may be exceeded if the input and output diode current ratings are observed.

RECOMMENDED OPERATING CONDITIONS

Symbol	Parameter	Min	Max	Unit
V _{CC}	Supply Voltage	1.65	5.50	V
S	Control Input Voltage (Note 2)	0	V _{CC}	V
V _{SW}	Switch Input Voltage	0	V _{CC}	V
T _A	Operating Temperature	-40	+85	°C
θ _{JA}	Thermal Resistance, Still Air		350	°C/W

Functional operation above the stresses listed in the Recommended Operating Ranges is not implied. Extended exposure to stresses beyond the Recommended Operating Ranges limits may affect device reliability.

2. Control Input must be held HIGH or LOW; it must not float.

FSA4159

DC ELECTRICAL CHARACTERISTICS

(All typical values are at 25°C unless otherwise specified.)

Symbol	Parameter	V _{CC} (V)	Conditions	Ambient Temperature (T _A)					Unit
				25°C			-40 to +85°C		
				Min.	Typ.	Max.	Min.	Max.	
V _{IH}	Input Voltage High	4.50 to 5.50					2.4		V
		3.00 to 3.60					2.4		
		2.30 to 2.70					1.8		
		1.65 to 1.95					1.5		
V _{IL}	Input Voltage Low	4.50 to 5.50						0.8	V
		3.00 to 3.60						0.8	
		2.30 to 2.70						0.6	
		1.65 to 1.95						0.6	
I _{IN}	Control Input Leakage	5.50	V _{IN} = 0 V or V _{CC}	-2		2	-100	100	nA
		3.60		-2		2	-100	100	
		2.70		-2		2	-20	20	
		1.95		-2		2	-20	20	
I _{NO(OFF)} , I _{NC(OFF)}	Off Leakage Current of Port B ₀ and B ₁	5.50	A = 1 V, 4.5 V, B ₀ or B ₁ = 4.5 V, 1.0 V	-10		10	-50	50	nA
		3.60	A = 1 V, 3.0 V, B ₀ or B ₁ = 3.0 V, 1.0 V	-10		10	-50	50	
		2.70	A = 0.5 V, 2.3 V, B ₀ or B ₁ = 2.3 V, 0.5 V	-10		10	-50	50	
		1.95	A = 0.3 V, 1.65 V, B ₀ or B ₁ = 1.65 V, 0.3 V	-5		5	-20	20	
I _{NO(ON)} , I _{NC(ON)}	On Leakage Current of Port B ₀ and B ₁	5.50	A = Float, B ₀ or B ₁ = 4.5 V, 1.0 V	-20		20	-100	100	nA
		3.60	A = Float, B ₀ or B ₁ = 3.0 V, 1.0 V	-10		10	-20	20	
		2.70	A = Float, B ₀ or B ₁ = 2.3 V, 0.5 V	-10		10	-20	20	
		1.95	A = Float, B ₀ or B ₁ = 1.65 V, 0.3 V	-5		5	-20	20	
I _{A(ON)}	On Leakage Current of Port A	5.50	A = 1 V, 4.5 V B ₀ or B ₁ = 1 V, 4.5 V, or Floating	-20		20	-100	100	nA
		3.60	A = 1 V, 3 V B ₀ or B ₁ = 1 V, 3 V, or Floating	-10		10	-20	20	
		2.70	A = 0.5 V, 2.3 V B ₀ or B ₁ = 0.5 V, 2.3 V, or Floating	-10		10	-20	20	
		1.95	A = 0.3 V, 1.65 V B ₀ or B ₁ = 0.3 V, 1.65 V, or Floating	-5		5	-20	20	
I _{OFF}	Power Off Leakage Current of Port A & Port B	0	A = 0 to 5.5 V B ₀ or B ₁ = 0 to 5.5 V		±1.00		-5.00	5.00	μA

FSA4159

DC ELECTRICAL CHARACTERISTICS (continued)

(All typical values are at 25°C unless otherwise specified.)

Symbol	Parameter	V _{CC} (V)	Conditions	Ambient Temperature (T _A)					Unit
				25°C			-40 to +85°C		
				Min.	Typ.	Max.	Min.	Max.	
R _{PEAK}	Peak On Resistance	4.50	I _{OUT} = -100 mA, B ₀ or B ₁ = 0 to V _{CC}		1.0	1.1		1.3	Ω
		3.00	I _{OUT} = -100 mA, B ₀ or B ₁ = 0 to V _{CC}		1.2	1.5		1.8	
		2.30	I _{OUT} = -8 mA, B ₀ or B ₁ = 0 to V _{CC}		1.5	2.0		2.5	
		1.65	I _{OUT} = 2 mA, B ₀ or B ₁ = 0 to V _{CC} T _A = 25, 85°C		4.0	10.0		15.0	
I _{OUT} = 2 mA, B ₀ or B ₁ = 0 to V _{CC} T _A = -40°C			10.0						
R _{ON}	Switch On Resistance (Note 3)	4.50	I _{OUT} = -100 mA, B ₀ or B ₁ = 2.5 V		0.8	0.9		1.1	Ω
		3.00	I _{OUT} = -100 mA, B ₀ or B ₁ = 2.0 V		1.0	1.3		1.6	
		2.30	I _{OUT} = -8 mA, B ₀ or B ₁ = 1.8 V		1.4	2.0		2.4	
		1.65	I _{OUT} = -2 mA, B ₀ or B ₁ = 1.5 V		1.7	2.5		3.5	
ΔR _{ON}	On Resistance Matching Between Channels (Note 4)	4.50	I _{OUT} = -100 mA, B ₀ or B ₁ = 2.5 V		0.05	0.10		0.10	Ω
		3.00	I _{OUT} = -100 mA, B ₀ or B ₁ = 2.0 V		0.10	0.15		0.15	
		2.30	I _{OUT} = -8 mA, B ₀ or B ₁ = 1.8 V		0.15	0.20		0.20	
		1.65	I _{OUT} = -2 mA, B ₀ or B ₁ = 1.5 V		0.15	0.40		0.40	
R _{FLAT(ON)}	On Resistance Flatness (Note 5)	4.50	I _{OUT} = -100 mA, B ₀ or B ₁ = 1.0 V, 1.5 V, 2.5 V		0.075	0.250		0.250	Ω
		3.00	I _{OUT} = -100 mA, B ₀ or B ₁ = 0.8 V, 2.0 V		0.1	0.3		0.3	
		2.30	I _{OUT} = -8 mA, B ₀ or B ₁ = 0.8 V, 1.8 V		0.2	1.0		1.0	
		1.65	I _{OUT} = -2 mA, B ₀ or B ₁ = 0.6 V, 1.5 V		3.5				
I _{CC}	Quiescent Supply Current	5.50	V _{IN} = 0 or V _{CC} , I _{OUT} = 0		10.0	50.0		500.0	nA
		3.60	V _{IN} = 0 or V _{CC} , I _{OUT} = 0		1.0	25.0		100.0	
		2.70	V _{IN} = 0 or V _{CC} , I _{OUT} = 0		0.5	20.0		50.0	
		1.95	V _{IN} = 0 or V _{CC} , I _{OUT} = 0		0.5	15.0		50.0	

Product parametric performance is indicated in the Electrical Characteristics for the listed test conditions, unless otherwise noted. Product performance may not be indicated by the Electrical Characteristics if operated under different conditions.

3. On resistance is determined by the voltage drop between A and B pins at the indicated current through the switch.

4. ΔR_{ON} = R_{ON max} - R_{ON min} measured at identical V_{CC}, temperature and voltage.

5. Flatness is defined as the difference between the maximum and minimum value of on resistance over the specified range of conditions.

FSA4159

AC ELECTRICAL CHARACTERISTICS

(All typical values are at $V_{CC} = 1.8\text{ V}, 2.5\text{ V}, 3.0\text{ V}, 5.0\text{ V}$ at 25°C unless otherwise specified.)

Symbol	Parameter	$V_{CC}(V)$	Conditions	Ambient Temperature (T_A)					Unit	Figure
				25°C			-40 to +85°C			
				Min.	Typ.	Max.	Min.	Max.		
t _{ON}	Turn-On Time	4.50 to 5.50	B_0 or $B_1 = V_{CC}$, $R_L = 50\ \Omega$, $C_L = 35\text{ pF}$	1	16	30	1	35	ns	Figure 11
		3.00 to 3.60		5	21	35	3	50		
		2.30 to 2.70		5	28	40	5	50		
		1.65 to 1.95		10	50	70	10	75		
t _{OFF}	Turn-Off Time	4.50 to 5.50	B_0 or $B_1 = V_{CC}$, $R_L = 50\ \Omega$, $C_L = 35\text{ pF}$	1	13	20	1	30	ns	Figure 11
		3.00 to 3.60		1	15	20	1	30		
		2.30 to 2.70		2	20	35	2	50		
		1.65 to 1.95		2.0	28	40	2	50		
t _{BBM}	Break-Before-Make Time	4.50 to 5.50	B_0 or $B_1 = V_{CC}$, $R_L = 50\ \Omega$, $C_L = 35\text{ pF}$		3.0		0.1	20.0	ns	Figure 12
		3.00 to 3.60			6.0		1.0	40.0		
		2.30 to 2.70		2.0	10.0	35.0	2.0	45.0		
		1.65 to 1.95			22.0		2.0	70.0		
Q	Charge Injection	5.50	$C_L = 1.0\text{ nF}$, $V_{GEN} = 0\text{ V}$, $R_{GEN} = 0\ \Omega$		15				pC	Figure 14
		3.30			11					
		2.50			8					
		1.65			6					
OIRR	Off Isolation	1.80 to 5.00	$f = 1\text{ MHz}$, $R_L = 50\ \Omega$		-60				dB	Figure 13
Xtalk	Crosstalk	1.80 to 5.00	$f = 1\text{ MHz}$, $R_L = 50\ \Omega$		-60				dB	Figure 13
BW	-3db Bandwidth	5.50	$R_L = 50\ \Omega$		180				MHz	Figure 7 Figure 8 Figure 16
		3.30			180					
		2.50			180					
		1.65			180					
THD	Total Harmonic Distortion	1.80	$R_L = 600\ \Omega$, $V_{IN} = 0.5\text{ V}_{PP}$, $f = 20\text{ Hz to }20\text{ kHz}$		0.006				%	Figure 10 Figure 17
		5.00			0.002					

CAPACITANCE

Symbol	Parameter	$V_{CC}(V)$	Conditions	$T_A = 25^\circ\text{C}$			Unit	Figure
				Min.	Typ.	Max.		
C _{IN}	Control Pin Input Capacitance	0	$f = 1\text{ MHz}$		3.5		pF	Figure 10
C _{OFF}	B Port Off Capacitance	1.65 to 5.50	$f = 1\text{ MHz}$		12.0		pF	Figure 10
C _{ON}	A Port On Capacitance	1.65 to 5.50	$f = 1\text{ MHz}$		40.0		pF	Figure 10

FSA4159

TYPICAL PERFORMANCE CHARACTERISTICS

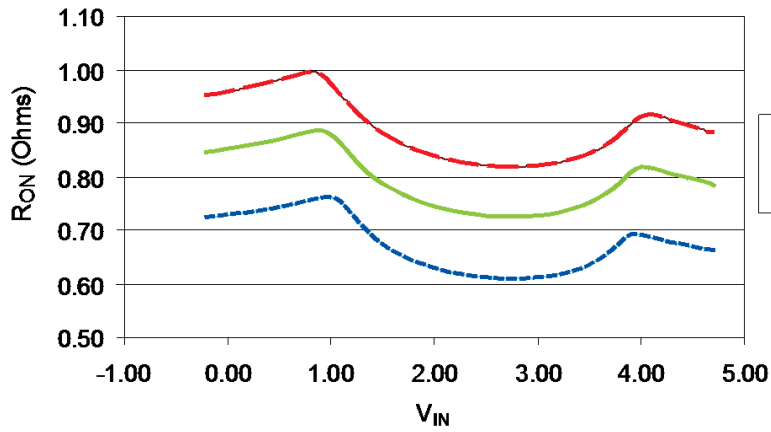

Figure 4. Switch RON (VCC = 4.5 V)

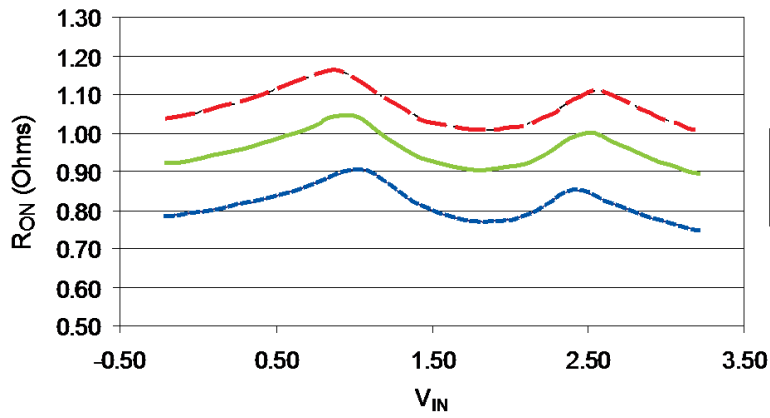

Figure 5. Switch RON (VCC = 3.0 V)

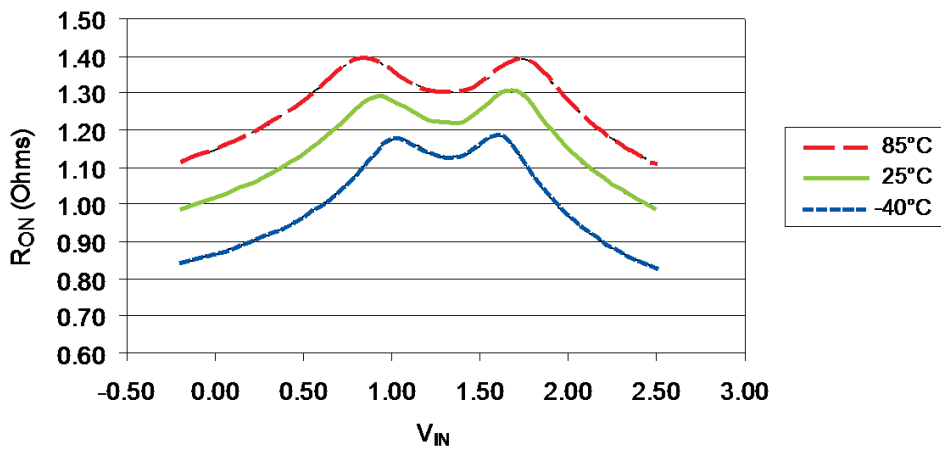

Figure 6. Switch RON (VCC = 2.3 V)

TYPICAL PERFORMANCE CHARACTERISTICS (Continued)

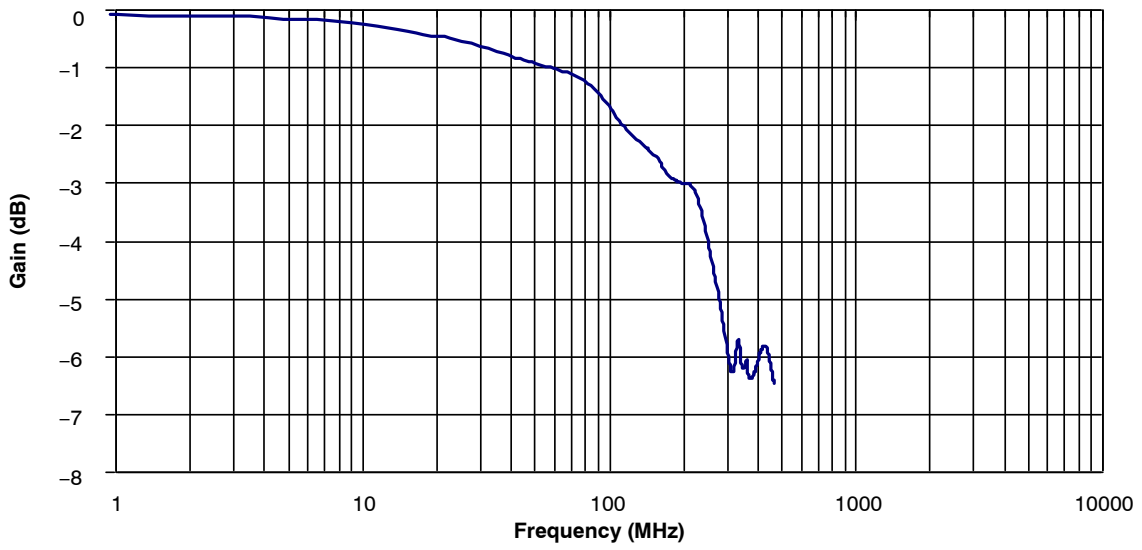

Figure 7. Frequency Response ($C_L = 0\text{ pF}$, $V_{CC} = 5.5\text{ V}$)

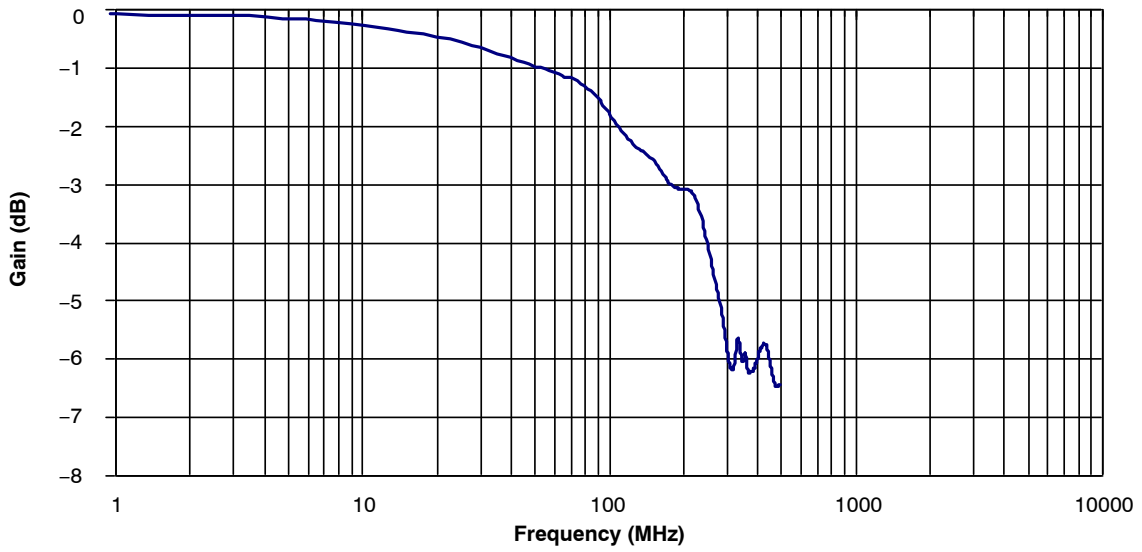

Figure 8. Frequency Response ($C_L = 0\text{ pF}$, $V_{CC} = 3.3\text{ V}$)

FSA4159

TYPICAL PERFORMANCE CHARACTERISTICS (Continued)

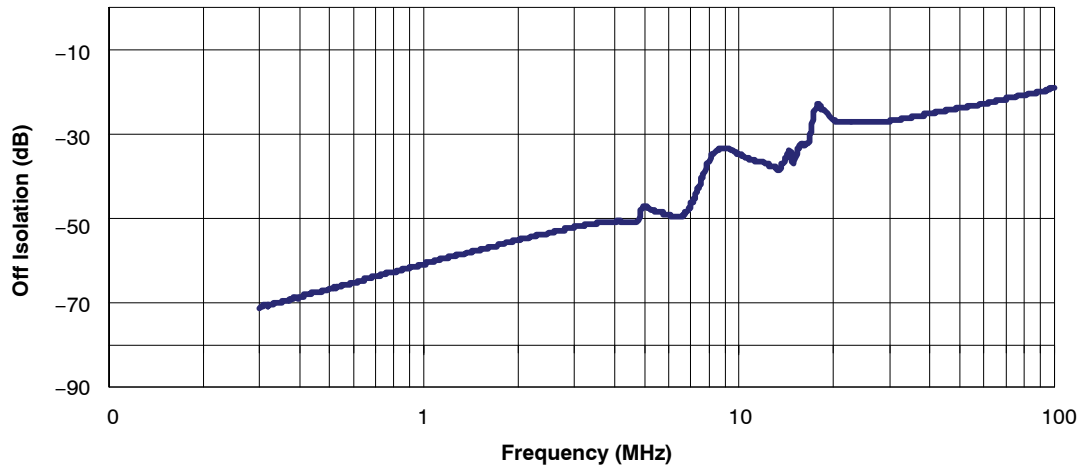

Figure 9. Off Isolation ($V_{CC} = 5.0$ V)

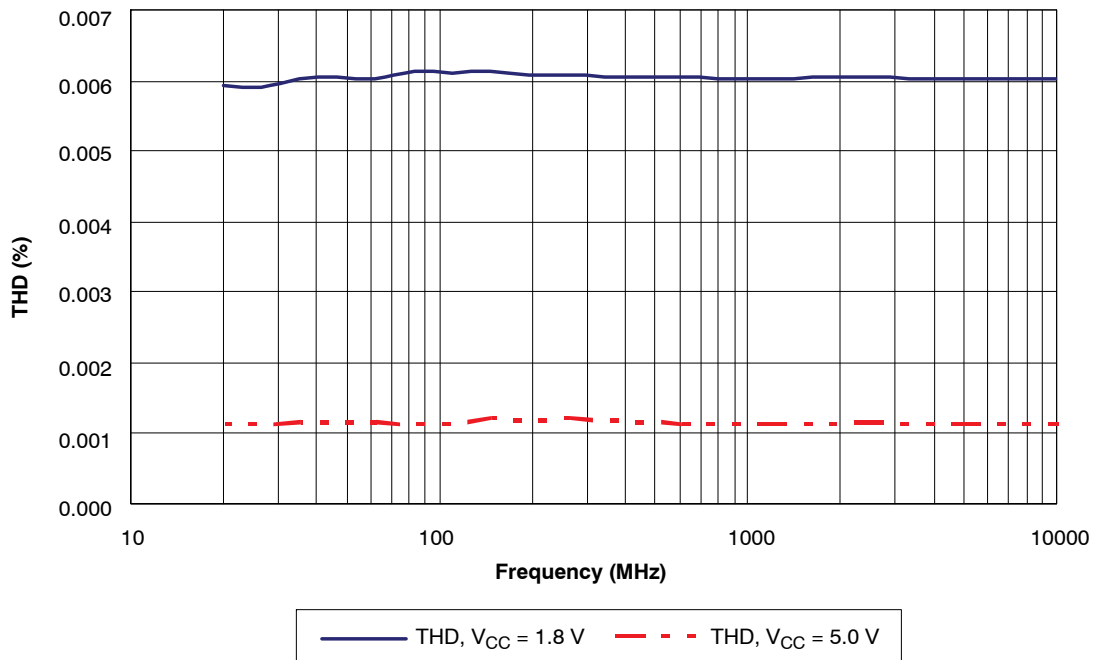

Figure 10. Total Harmonic Distortion, Frequency Response ($C_L = 0$ pF)

TEST DIAGRAMS

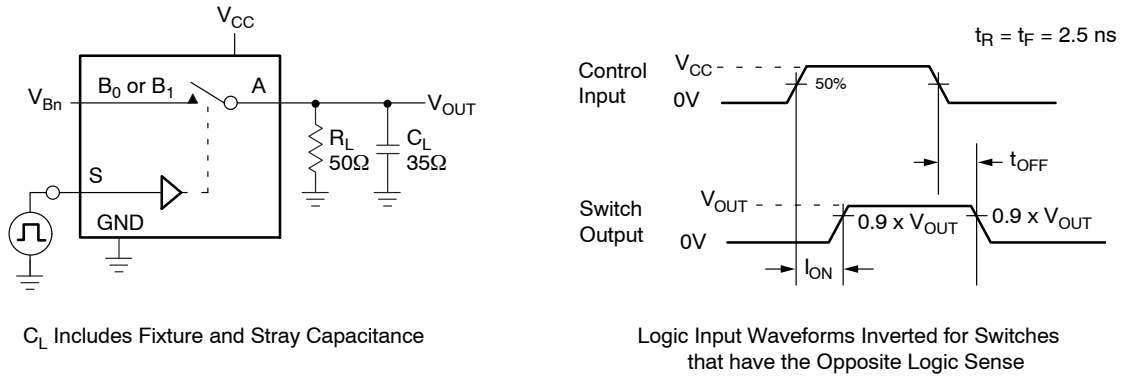

Figure 11. Turn On / Off Timing

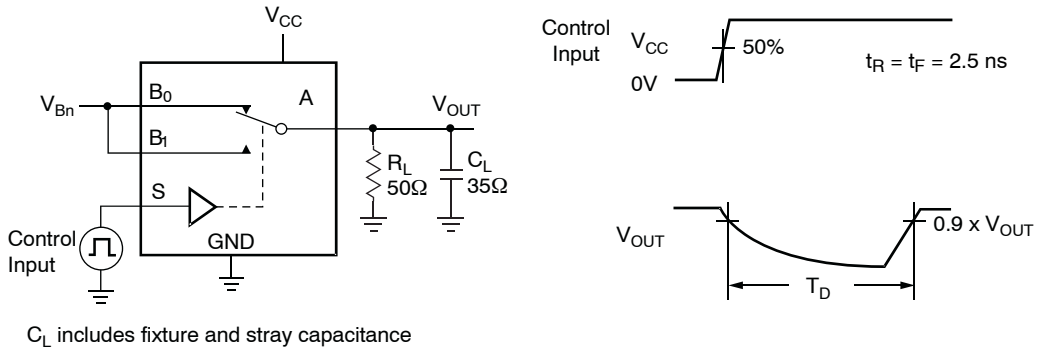

Figure 12. Break-Before-Make Timing

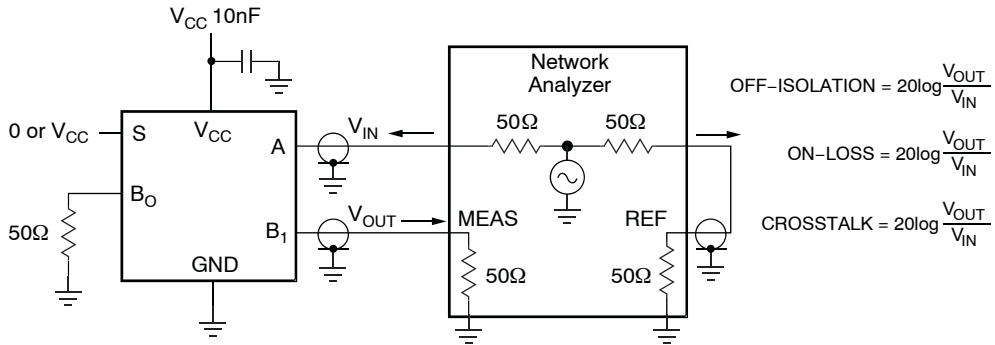

Figure 13. Off Isolation and Crosstalk

FSA4159

TEST DIAGRAMS (Continued)

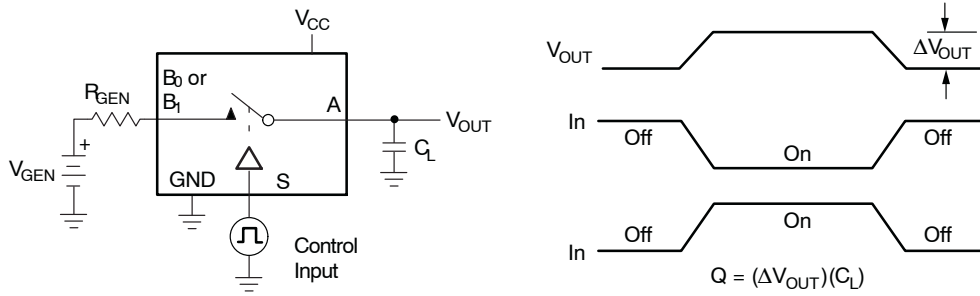

Figure 14. Charge Injection

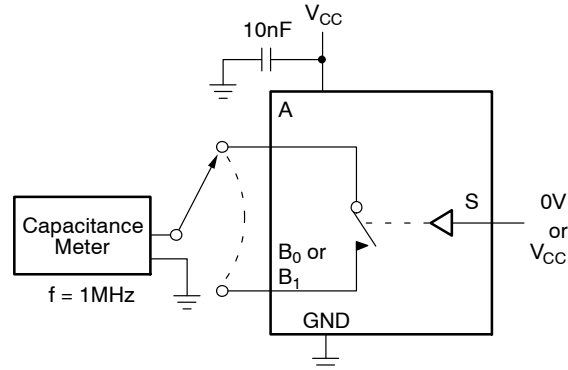

Figure 15. On / Off Capacitance Measurement Setup

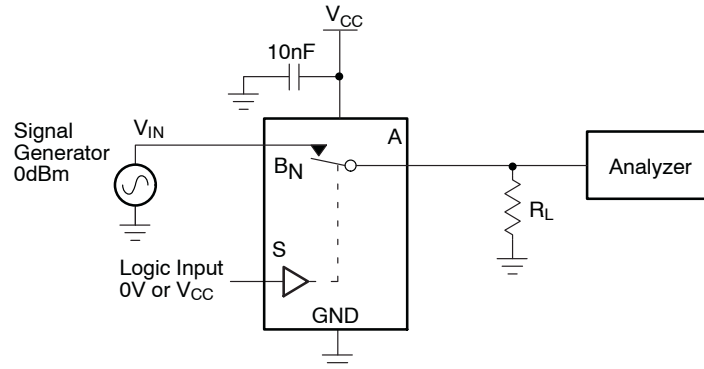

Figure 16. Bandwidth

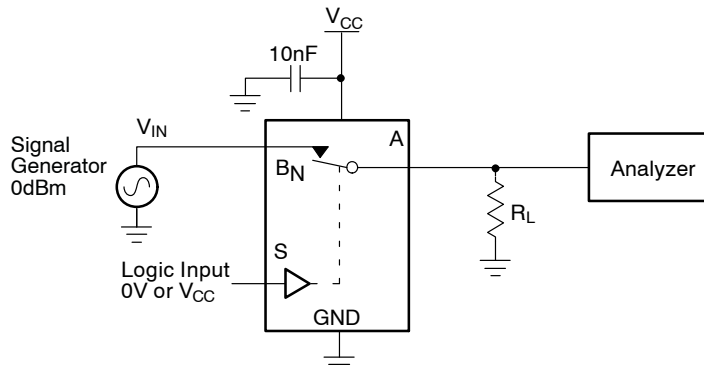
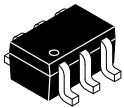

Figure 17. Harmonic Distortion

MicroPak is a trademark of Semiconductor Components Industries, LLC dba "onsemi" or its affiliates and/or subsidiaries in the United States and/or other countries.

MECHANICAL CASE OUTLINE
PACKAGE DIMENSIONS



1

SC-88 (SC-70 6 Lead), 1.25x2
CASE 419AD
ISSUE A

DATE 07 JUL 2010

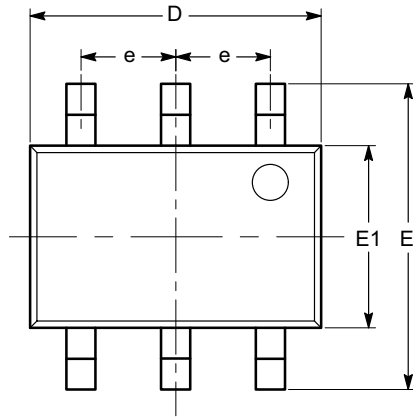

TOP VIEW

SYMBOL	MIN	NOM	MAX
A	0.80		1.10
A1	0.00		0.10
A2	0.80		1.00
b	0.15		0.30
c	0.10		0.18
D	1.80	2.00	2.20
E	1.80	2.10	2.40
E1	1.15	1.25	1.35
e	0.65 BSC		
L	0.26	0.36	0.46
L1	0.42 REF		
L2	0.15 BSC		
θ	0°		8°
θ_1	4°		10°

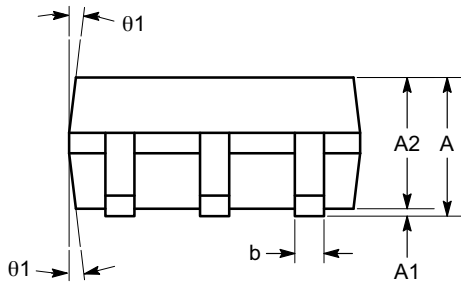

SIDE VIEW

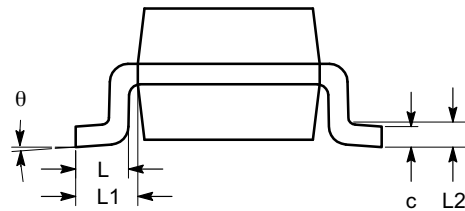

END VIEW

Notes:

- (1) All dimensions are in millimeters. Angles in degrees.
- (2) Complies with JEDEC MO-203.

DOCUMENT NUMBER:	98AON34266E	Electronic versions are uncontrolled except when accessed directly from the Document Repository. Printed versions are uncontrolled except when stamped "CONTROLLED COPY" in red.
DESCRIPTION:	SC-88 (SC-70 6 LEAD), 1.25X2	PAGE 1 OF 1

onsemi and ONSEMI are trademarks of Semiconductor Components Industries, LLC dba onsemi or its subsidiaries in the United States and/or other countries. onsemi reserves the right to make changes without further notice to any products herein. onsemi makes no warranty, representation or guarantee regarding the suitability of its products for any particular purpose, nor does onsemi assume any liability arising out of the application or use of any product or circuit, and specifically disclaims any and all liability, including without limitation special, consequential or incidental damages. onsemi does not convey any license under its patent rights nor the rights of others.

onsemi, **Onsemi**, and other names, marks, and brands are registered and/or common law trademarks of Semiconductor Components Industries, LLC dba "**onsemi**" or its affiliates and/or subsidiaries in the United States and/or other countries. **onsemi** owns the rights to a number of patents, trademarks, copyrights, trade secrets, and other intellectual property. A listing of **onsemi**'s product/patent coverage may be accessed at www.onsemi.com/site/pdf/Patent-Marking.pdf. **onsemi** reserves the right to make changes at any time to any products or information herein, without notice. The information herein is provided "as-is" and **onsemi** makes no warranty, representation or guarantee regarding the accuracy of the information, product features, availability, functionality, or suitability of its products for any particular purpose, nor does **onsemi** assume any liability arising out of the application or use of any product or circuit, and specifically disclaims any and all liability, including without limitation special, consequential or incidental damages. Buyer is responsible for its products and applications using **onsemi** products, including compliance with all laws, regulations and safety requirements or standards, regardless of any support or applications information provided by **onsemi**. "Typical" parameters which may be provided in **onsemi** data sheets and/or specifications can and do vary in different applications and actual performance may vary over time. All operating parameters, including "Typicals" must be validated for each customer application by customer's technical experts. **onsemi** does not convey any license under any of its intellectual property rights nor the rights of others. **onsemi** products are not designed, intended, or authorized for use as a critical component in life support systems or any FDA Class 3 medical devices or medical devices with a same or similar classification in a foreign jurisdiction or any devices intended for implantation in the human body. Should Buyer purchase or use **onsemi** products for any such unintended or unauthorized application, Buyer shall indemnify and hold **onsemi** and its officers, employees, subsidiaries, affiliates, and distributors harmless against all claims, costs, damages, and expenses, and reasonable attorney fees arising out of, directly or indirectly, any claim of personal injury or death associated with such unintended or unauthorized use, even if such claim alleges that **onsemi** was negligent regarding the design or manufacture of the part. **onsemi** is an Equal Opportunity/Affirmative Action Employer. This literature is subject to all applicable copyright laws and is not for resale in any manner.

ADDITIONAL INFORMATION

TECHNICAL PUBLICATIONS:

Technical Library: www.onsemi.com/design/resources/technical-documentation
onsemi Website: www.onsemi.com

ONLINE SUPPORT: www.onsemi.com/support

For additional information, please contact your local Sales Representative at www.onsemi.com/support/sales